

---

# Basic Quantifier Theory

JAAP VAN DER DOES AND JAN VAN EIJCK

## 1 Preamble

According to Lindström 1966 a quantifier is a functor which assigns to each non-empty domain a relation among relations which is closed under isomorphisms. A simple instance of this notion is given by the quantifier ‘more than half of the’, which for each domain  $E$  gives the relation between sets  $A, B \subseteq E$  defined by:

$$|\{a \in A : a \in B\}| > |\{a \in A : a \notin B\}|$$

In the present collection of articles the authors investigate several aspects of such quantifiers, also of quantifiers with relational arguments.

This introduction presents some basic insights and techniques of quantification theory. After a brief history, we pay attention to application of the theory in linguistics, and then to its more logical features. The linguistic topics include: denotational constraints, behaviour in certain linguistic contexts, and polyadic forms of quantification. On the logical side, we discuss metaproperties of weak and of ‘real’ quantifier logics. In particular, we concentrate on the tableau method for weak quantifier logics, and on decidability results.

It is impossible to write an introduction to this field which does not overlap with the comprehensive overviews in Westerståhl 1989, van Eijck 1991, Keenan and Westerståhl 1995, Westerståhl 1995, and the reader is encouraged to study some of these as well. For surveys of recent work we recommend van Benthem and Westerståhl 1994, Westerståhl 1995, Keenan and Westerståhl 1995.

## 2 A Trace of History

### 2.1 Aristotle

Aristotle was already aware that quantifiers play a key rôle in the process of making inferences, so ever since Aristotle's day quantification is a central topic in logic. In his theory of the syllogism, Aristotle studied the following inferential pattern:

$$\frac{\text{Quantifier}_1 \text{ Restriction}_1 \text{ Body}_1}{\text{Quantifier}_2 \text{ Restriction}_2 \text{ Body}_2} \\ \text{Quantifier}_3 \text{ Restriction}_3 \text{ Body}_3$$

As an example we give the valid syllogism FESTINO:

$$\frac{\text{No A are B} \\ \text{Some C are B}}{\text{Some C are not A}}$$

Syllogistic theory focusses on the quantifiers in the so-called *Square of Opposition* given in figure 1. The quantifiers in the square express relations

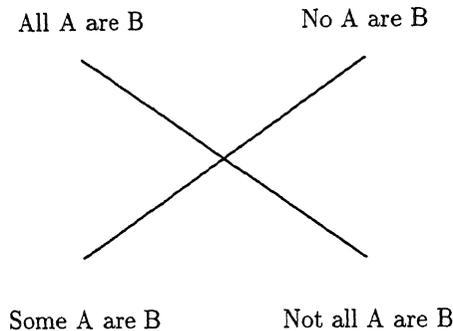

FIGURE 1 The Aristotelian Square of Opposition

between a first and a second argument (the restriction and the body), where both arguments denote sets of entities taken from some domain of discourse. In the square the quantified expressions are related across the diagonals by *external* (sentential) negation, and across the horizontal edges by *internal* (or verb phrase) negation. It follows that the relation across the vertical edges of the square is that of internal plus external negation; this is the relation of quantifier *duality*.

Aristotle interprets his quantifiers with *existential import*: *All A are B* and *No A are B* are taken to imply that there are *A*. Under this assumption, the quantified expressions at the top edge of the square imply those immediately below them. The universal affirmative quantifier *all* implies the individual affirmative *some* and the universal negative *no* implies

the individual negative *not all*. Existential import also makes that the two quantified expressions on the top edge of the square cannot both be true; these expressions are called *contraries*. For the same reason, the two quantified expressions on the bottom edge cannot both be false: they are so-called *subcontraries*. See van Benthem 1984, and van Eijck 1985 for information on the connection between syllogistics and generalized quantifier theory.

Aristotle's syllogistics is quite an impressive theory of quantification, but it has some shortcomings. In the first place, quantifier combinations are not treated: only one quantifier per sentence is allowed. Secondly, 'non-standard quantifiers' such as *most*, *half of the*, *at least five*, ... are not covered. A minor additional flaw is the assumption of existential presupposition. In mathematical reasoning, and sometimes also in everyday reasoning, one wants to be able to assert universally quantified statements without assuming existence. Cf. De Jong and Verkuyl 1985 for a discussion.

## 2.2 Frege, Peirce

Independently, Gottlob Frege and Charles Sanders Peirce invented predicate logic, and the theory of quantification that goes with it. Their approaches are based on the introduction of *individual variables* bound by the quantifiers  $\forall$  ('for all') and  $\exists$  ('there exists'). These are the so-called standard quantifiers. This account of quantification removes the first of the three defects of the Aristotelian theory. Quantifiers with their associated variables can combine with arbitrarily complex predicate logical formulae to form new predicate logical formulae, and a formula may contain an arbitrary number of quantifiers.

The quantifiers  $\forall$  and  $\exists$  are interdefinable with the help of negation: *Something is rotten* means the same as *It is not so for every  $x$  that  $x$  is not rotten*, and *Everybody is happy* means the same as *It is not so that there is a person  $x$  who is not happy*. More formally:  $\exists xAx$  is true if and only if  $\neg\forall x\neg Ax$  is true, and  $\forall xAx$  is true if and only if  $\neg\exists x\neg Ax$  is true. On this view, the Square of Opposition looks like figure 2. Apart from the existential presuppositions, the Aristotelian quantifiers from the Square of Opposition can be expressed in terms of the Fregean standard quantifiers, as follows (with  $\rightsquigarrow$  for 'translates as'):

<i>All A are B</i>	$\rightsquigarrow$	$\forall x(Ax \rightarrow Bx)$
<i>Some A is/are B</i>	$\rightsquigarrow$	$\exists x(Ax \wedge Bx)$
<i>No A is B</i>	$\rightsquigarrow$	$\forall x(Ax \rightarrow \neg Bx)$
<i>Not all A are B</i>	$\rightsquigarrow$	$\exists x(Ax \wedge \neg Bx)$

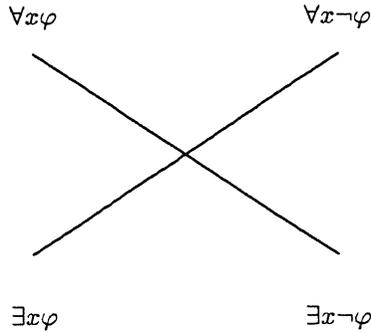

FIGURE 2 The Fregean Square of Opposition

If one takes the existential presuppositions into account, the translations become:

$$\begin{array}{ll}
 \text{All } A \text{ are } B & \rightsquigarrow \exists xAx \wedge \forall x(Ax \rightarrow Bx) \\
 \text{Some } A \text{ is/are } B & \rightsquigarrow \exists x(Ax \wedge Bx) \\
 \text{No } A \text{ is } B & \rightsquigarrow \exists xAx \wedge \forall x(Ax \rightarrow \neg Bx) \\
 \text{Not all } A \text{ are } B & \rightsquigarrow \exists x(Ax \wedge \neg Bx)
 \end{array}$$

Note that these translations make the presupposition a part of the assertion.

### 2.3 Mostowski, Lindström

Full generality was attained in the relational perspective on quantifiers, which is due to Mostowski 1957 and Lindström 1966. On this view a (simple binary) quantifier is a two-place relation on the power set of a domain  $E$  satisfying certain constraints (cf. section 3.2). The power set of  $E$ , notation  $\wp(E)$ , is the set of all subsets of  $E$ , so a two-place relation on  $\wp(E)$  is a set of pairs of subsets of  $E$ . This perspective on quantification was first systematically applied to natural language analysis in Barwise and Cooper 1981, Higginbotham and May 1981, Keenan and Stavi 1986, and van Benthem 1984, 1986.

The relational view covers non-standard quantifiers, it allows combinations of arbitrary complexity, it does not syntactically eliminate quantified noun phrases, and it can be used as one of the ingredients in a *non ad hoc* translation procedure from natural language to a language of logical representations. In short, it removes most of the defects of its predecessors, and it is so eminently suited for natural language analysis that generalized quantifiers theory has become a showcase of interaction between logic and linguistics.

### 3 Linguistic Issues

On the linguistic side, quantifier theory has several things to offer. In the first place, it provides the means for a compositional semantics for natural language sentences. Secondly, it gives insight into which natural language determiners are realized among the many possibilities. Thirdly, it describes and sometimes even explains the behaviour of noun phrases in particular linguistic contexts. Finally, it allows us to give the truth-conditions for sentences which are hard to understand otherwise. In this section, we give examples of all these features of the theory.

#### 3.1 Misleading Form vs. Compositionality

In a previous era of natural language semantics, initiated by Russell and Wittgenstein, the familiar formulation of first-order predicate logic was considered the one and only tool for semantic analysis. As a consequence, quantified noun phrases were commonly regarded as systematically misleading expressions. This is called the *misleading form thesis*.

Consider the translation of example (1).

- (1) Every farmer bought a cow.  
 $\forall x(Fx \rightarrow \exists y(Cy \wedge Bxy))$ .

Example (1) illustrates that first-order logic has no difficulty with quantifier combinations. But observe that the translation does not contain phrases corresponding to the noun phrases *every farmer* or *a cow*. Given a natural language sentence and its translation into first-order logic, as presented in the familiar way, it is impossible to pinpoint the subexpression in the translation that gives the meaning of a particular noun phrase in the original. In the translation into first-order logic, the noun phrases have been syntactically eliminated, so to speak. This illustrates that the natural language syntax of quantified expressions does not correspond to this predicate logical syntax. In natural language, quantified noun phrases are separate constituents, but they evaporate during the process of translation into first-order logic.

To demonstrate that in the relational perspective on quantification the suggestion of misleading form disappears, we consider two simple example sentences. We show that a representation language with generalized quantifier expressions (expressions denoting two place relations between sets) and a notation for lambda abstraction is well suited for the compositional analysis of natural language sentences with quantified noun phrases.

First consider example (2).

- (2) Every woman smiled.

This sentence is composed of a noun phrase *every woman*, composed in turn of a determiner *every* and a noun *woman*, and a verb phrase *smiled*.

The determiner *every* translates into an expression **every** denoting a function from properties to a function from properties to truth values. More precisely, **every** denotes the function mapping property **P** to (the characteristic function of) the set of all properties having **P** as a subset. The noun *woman* translates into  $\lambda x.Wx$ , the verb phrase *smiled* into  $\lambda y.Sy$ , the noun phrase *every woman* into **every**( $\lambda x.Wx$ ), and, finally, the whole sentence into the expression (**every**( $\lambda x.Wx$ ))( $\lambda y.Sy$ ). The reader is urged to check that this expression yields true in case the property of being a woman is included in the property of smiling, false otherwise.

As a second example we consider example (1) again, also to see how quantifier combinations are dealt with compositionally. The trick is finding the right translation for the transitive verb. This turns out to be the lambda expression  $\lambda X\lambda y.X(\lambda z.Byz)$ , where **X** is a variable over noun phrase type expressions. The verb translation is of the right type to take the object noun phrase translation as its argument; this gives translation (3a) for the verb phrase, which reduces to (3b).

- (3) a.  $\lambda X\lambda y.X(\lambda z.Byz)(\mathbf{a}(\lambda u.Cu))$   
 b.  $\lambda y.(\mathbf{a}(\lambda u.Cu))(\lambda z.Byz)$

Here **a** denotes the function which maps every property **P** to (the characteristic function of) the set of all properties having a non-empty overlap with **P**. Feeding (3b) as argument to the expression **every**( $\lambda x.Fx$ ), the translation of the subject, one gets (4) as translation for the whole sentence.

- (4) (**every**( $\lambda x.Fx$ ))( $\lambda y.(\mathbf{a}(\lambda u.Cu))(\lambda z.Byz)$ ).

This translation can still be simplified somewhat, by writing *F* and *C* for the property denoting expressions  $\lambda x.Fx$  and  $\lambda u.Cu$ , respectively.

- (5) (**every**(*F*))( $\lambda y.(\mathbf{a}(C))(\lambda z.Byz)$ ).

The compositional semantic analysis of natural language sentences involving quantifiers is the reverse of the process of compositional synthesis demonstrated here.

### 3.2 Quantifier Constraints

The sentence *All men walk* is true in a given model if and only if the relation of inclusion holds between the set of men in the model and the set of walkers in the model. Abstracting from the domain of discourse, we can say that determiner interpretations (henceforth: determiners) pick out binary relations on sets of individuals, on arbitrary universes (or: domains of discourse) *E*. Notation:  $D_EAB$ . We call *A* the *restriction* of the quantifier and *B* its *body*. If  $D_EAB$  is the translation of a simple sentence consisting of a quantified noun phrase with an intransitive verb phrase then the noun

denotation is the restriction and the verb phrase denotation the body. See figure 3 for a graphical representation.

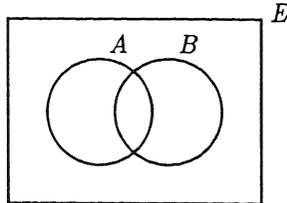

FIGURE 3 Quantifiers as Relations

A simple binary quantifier  $D$  on a domain  $E$  is a relation between subsets of  $E$ :

$$D_E \in \wp(\wp(E) \times \wp(E))$$

The trivial quantifiers are  $\top_E$  and  $\perp_E$ , which hold of all and of no pairs of sets, respectively.

Not all elements in  $\wp(\wp(E) \times \wp(E))$  serve as natural language determiner denotations. In fact, one of the first insights provided by quantification theory is that such determiners have to satisfy some constraints. A first requirement is *extension*:

**EXT** For all  $A, B \subseteq E \subseteq E'$ :  $D_E AB \Leftrightarrow D_{E'} AB$ .

A relation observing EXT is stable under growth of the universe. So, given sets  $A$  and  $B$ , only the objects in the minimal universe  $A \cup B$  matter. See figure 4.

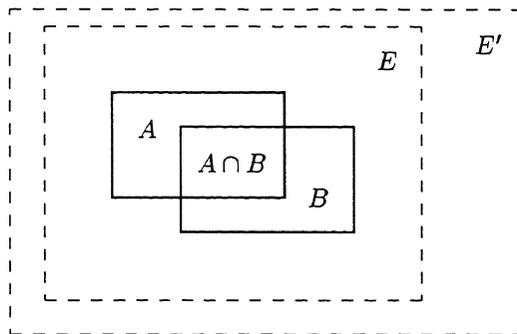

FIGURE 4 The Effect of EXT

An example of a natural language determiner which does not satisfy EXT is *many* in the sense of *relatively many*:

$$|A \cap B| > 0.5 * |E|$$

In this sense *many* crucially depends on  $E$ .

A second requirement for quantifier relations is *conservativity*:

**CONS** For all  $A, B \subseteq E$ :  $D_E AB \Leftrightarrow D_E AA \cap B$ .

In the context of EXT, this property expresses that the first argument of a relation (the interpretation of the noun) plays a crucial rôle: it sets the stage, in the sense that everything outside the extension of the first argument is irrelevant.

There are a few noun phrase determiners which do not satisfy CONS. One example is *only* as in (6).

(6) Only men came to the party.

This example is true in a situation where all partygoers were men; **only** denotes the superset relation:  $\supseteq$ . Starting out from a situation like this, and adding some women to the partygoers will make (6) false. This shows non-conservativity. All is still well if it can be argued that noun phrases starting with *only*, *mostly* or *mainly* (two other sources of non-conservativity) are exceptional syntactically, in the sense that these noun phrase prefixes are not really determiners. In the case of *only*, it could be argued that *only men* has structure  $[np[_{mod} \text{only}][np \text{men}]]$ , with *only* not a determiner but a noun phrase modifier, just as in (7).

(7) Only John came to the party.

See De Mey, this volume, for more information concerning *only*.

Despite the small number of counterexamples, separating out the determiners satisfying CONS and EXT is important, for the combination of EXT and CONS is equivalent to the principle UNIV:

**UNIV** For all  $A, B \subseteq E$ :  $D_E AB \Leftrightarrow D_A AA \cap B$ .

The right-handside of this equivalence shows that for UNIV  $D$  the truth of  $D_E AB$  only depends on the sets  $A$  and  $A \cap B$ ; or, on finite domains equivalently, on the sets  $A - B$  and  $A \cap B$  (respectively, the things which are  $A$  but not  $B$ , and the things which are both  $A$  and  $B$ ). See figure 5.

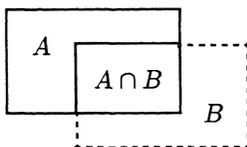

FIGURE 5 The Combined Effect of EXT and CONS

An UNIV determiner still lacks the property that it is only sensitive to the cardinalities of the sets  $A - B$  and  $A \cap B$ . But such insensitivity is something one would surely expect from a *quantifier*. The relational perspective suggests a very natural way of distinguishing between expressions of quantity and other relations. Quantifier relations satisfy the following condition of *isomorphy*, formulated in terms of bijections.

**ISOM** If  $f$  is a bijection from  $E$  to  $E'$ , then  $D_E AB \Leftrightarrow D_{E'} f[A]f[B]$ .

Here  $f[A]$ , the image of  $A$  under  $f$ , is the set of all things which are  $f$ -values of things in  $A$ . If  $D$  satisfies EXT, CONS and ISOM, it turns out that the truth of  $DAB$  depends only on the cardinal numbers  $|A - B|$  and  $|A \cap B|$ . See figure 6 for the combined effect of these three conditions, and section 4.3 for a proof. By definition a quantifier is a relation  $D$  satisfying EXT, CONS and ISOM.

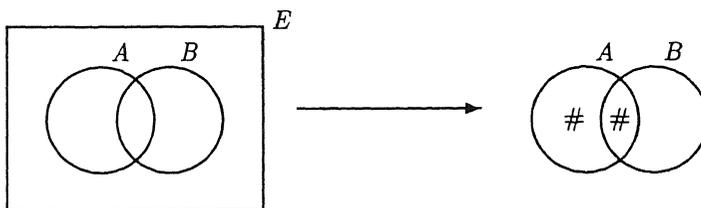

FIGURE 6 The Combined Effect of EXT, CONS, ISOM

The semantic effect of a quantifier  $DAB$  can always be described in terms of the properties of the numbers  $|A - B|$  and  $|A \cap B|$ . *All A are B* is true if and only if the number of things which are  $A$  and not  $B$  is 0. *Some A is B* is true if and only if the number of things that are both  $A$  and  $B$  is at least 1. *Most A are B* is true if and only if the number of things that are both  $A$  and  $B$  exceeds the number of things that are  $A$  and not  $B$ . Some further examples are in section 4.3.1.

### 3.3 Distribution and Logical Behaviour

We now turn to the distribution of noun phrases in existential sentences, and to their logical behaviour in naked infinitive perception reports.

#### 3.3.1 Existential Sentences

Not all noun phrases may occur in so-called existential sentences. For instance, the noun phrases in (8a) are acceptable while those in (8b) are not.

- (8) a. There are two/some/no students at the party
- b. \*There are all/the/not all students at the party

In Milsark 1977 the noun phrases which are allowed in these contexts are categorized as the *weak* ones, while those who are not he calls *strong*. (Weak determiners are also called 'indefinite'.) Barwise and Cooper 1981 give these notions semantical content by means of familiar relational properties:

**Definition 1** A determiner  $D$  is *positive strong* iff  $D$  is reflexive:

$$\forall X.DXX$$

$D$  is *negative strong* iff  $D$  is irreflexive:

$$\forall X.\neg DXX$$

$D$  is *strong* iff  $D$  is either positive or negative strong.  $D$  is *weak* iff  $Q$  is not strong.

It accords nicely with Milsark's taxonomy that *two*, *some*, and *no* are weak in this semantic sense. Typical examples of strong quantifiers are *all* and *not all*. Indeed, the positive strong conservative determiners extend *all*, while the negative strong ones are part of *not all*. E.g., if  $A \subseteq B$ , then by conservativity and reflexivity:  $DAA$ ,  $DAA \cap B$ ,  $DAB$ . So,  $all \subseteq D$ .

The proposal of Barwise and Cooper offers an explanation of why strong noun phrases cannot occur in existential sentences. A sentence of the form (9a) can be said to be true (relative to a domain  $E$ ) iff (9b) is true.

- (9) a. There are  $[_{np} \text{DET } N]$   
 b.  $[\text{DET}]_E[N]E$

In case the determiner is conservative this would mean that (9a) is true iff  $[\text{DET}]_E[N][N]$ . So, in an existential sentence positive strong determiners yield logical truths, while negative strong determiners yield contradictions. But a simple existential sentence is contingent: sometimes true, sometimes false.

A problem for the above proposal is that all proportional determiners *n% of the* are semantically weak:

$$n \% \text{ of the } AB \Leftrightarrow |A \cap B| \geq n/100 * |A|$$

but none of them is acceptable in an existential sentence.

- (10) \*There are five percent of the students at the party

These counterexamples suggest to redefine the weak determiners as the *symmetric* ones. This notion of weakness is more restrictive than that of Barwise and Cooper. Assuming conservativity, it can be seen that the only strong symmetric determiners are the trivial  $\top$  and  $\perp$ . For  $DAB$  iff (conservativity)  $DAA \cap B$  iff (symmetry)  $DA \cap BA$  iff (conservativity)  $DA \cap BA \cap B$ , and the latter is always true or always false for strong determiners. Therefore, non-trivial symmetric determiners are weak.

Identifying weakness with symmetry squares well with attempts to generalize the notion to determiners of higher arities, such as the comparative determiners *more than*, *as many as*, *fewer than*, which are 3-place determiners. These all occur felicitously in existential sentences.

- (11) a. **as many as**  $ABC \Leftrightarrow |A \cap B| = |A \cap C|$   
 b. There are as many students as teachers at the party

A proposal for a generalization of *weakness* by Keenan 1987a is to identify the indefinite (or weak) determiners with the intersective ones (the following definition is equivalent to Keenan's):

**Definition 2** An  $n$ -place determiner  $D$  is intersective iff  $D$  is conservative and  $DA_1 \dots A_n B \Leftrightarrow DA_1 \cap B \dots A_n \cap BB$ .

Keenan's formalization of weakness is as general as one would like it to be. To see that it generalizes the notion of symmetry to the  $n$ -ary case, note that binary conservative determiners are intersective iff they are symmetric. For assume that  $D$  is symmetric. Then  $DAB$  iff (conservativity)  $DAA \cap B$  iff (symmetry)  $DA \cap BA$  iff (conservativity)  $DA \cap BA \cap B$  iff (conservativity)  $DA \cap BB$ . Conversely, if we assume that  $D$  is intersective, then  $DAB$  iff (intersectivity)  $DA \cap BB$  iff (conservativity)  $DA \cap BA \cap B$  iff (intersectivity)  $DBA \cap B$  iff (conservativity)  $DBA$ . It follows that Keenan's proposal is empirically more adequate than that of Barwise and Cooper: the proportional determiners are not intersective but numerals and comparatives are.

### 3.3.2 Naked Infinitive Perception Reports

Studying quantifiers in a partial setting is necessary, among other things, to be able to deal with the semantics of naked infinitive perception reports (Barwise 1981, Barwise and Perry 1983, Higginbotham 1983, Kamp 1984, Asher and Bonevac 1987, Asher and Bonevac 1989). Examples of such perception reports are in (12a-c), where the complement of the perception verb is unconjugated.

- (12) a. I saw some bears prepare sandwiches.  
 b. I saw no bears prepare sandwiches.  
 c. I saw two bears prepare sandwiches.

A key feature of the semantics of naked infinitives is the fact that sentences like (13) have a reading which does not imply variants where the perception complement is replaced by a classically equivalent complement, as in (13a,b).

- (13) a. I saw John help Mary.  
 b. I saw John help Mary and help Bill or not help Bill.

In a classical framework the complements in (13a,b) are logically equivalent, so the semantic distinction between the two examples gets lost. To

preserve it one must distinguish between partial models (or situations) supported by what I saw, partial models refuted by what I saw, and partial models untouched by what I saw. This threefold distinction accounts for the difference between (13a) and (13b), for it may be that a situation where John helps Mary is supported by what I saw, while on the other hand none of the situations supported by what I saw have Bill in it.

The switch to a partial perspective involves for every predicate  $P$  a distinction between things satisfying  $P$ , things not satisfying  $P$ , and things doing neither. Restricting attention to the case of predicates  $A$  on a universe  $E$ , a partial predicate  $A$  divides  $E$  in a region of things that do satisfy  $A$  (call this set  $A^+$ ), a region of things that do not satisfy  $A$  (call this set  $A^-$ ) and a region of things with unknown  $A$  status (call this set  $A^*$ ).

Now, the starting point of the logical investigation of naked infinitives is the following question: which quantifier property licences the inference called *veridicality* in (14)?

(14) I saw DAB./ Therefore: DAB.

In this regard notice that from the truth of sentence (12a) it follows that some bears were indeed preparing sandwiches, so (15a) is a consequence of (12a).

- (15) a. Some bears were preparing sandwiches.  
 b. No bears were preparing sandwiches.  
 c. Two bears were preparing sandwiches.

But from the truth of (12b) it does not follow that no bears were preparing sandwiches, so (15b) is not a consequence of (12b). The same holds for the relation between (12c) and (15c), in case ‘two’ is understood as ‘exactly two’. For ‘at least two’ (15c) does follow from (12c).

A considerable part of the logic of naked infinitives can be studied by restricting the partialisation to the non-logical relations in the way indicated. Given this much, van der Does 1991 considers, among other things, naked infinitive complements which consist of an iteration of noun phrases. Following up on observations by Barwise, Higginbotham, and Asher and Bonevac, he characterizes the iterations that validate veridicality as precisely those which consist of  $\text{MON}\uparrow$  noun phrases except perhaps for an even number of  $\text{MON}\downarrow$  ones. These notions are defined as follows.

**Definition 3** The *right monotone* determiners  $D$  are those with:

$\text{MON}\uparrow$ : if  $DAB$  and  $B \subseteq B'$ , then  $DA'B'$ .

$\text{MON}\downarrow$ : If  $DAB$  and  $B' \subseteq B$  then  $DA'B'$ .

The *left monotone* determiners  $D$  have:

$\uparrow\text{MON}$ : If  $DAB$  and  $A \subseteq A'$  then  $DA'B$ .

$\downarrow\text{MON}$ : If  $DAB$  and  $A' \subseteq A$  then  $DA'B$ .

Examples of  $\text{MON}\uparrow$  determiners are: *all*, *some*, *at least two*, while *Not all* and *no* are  $\text{MON}\downarrow$  determiners. *Some* and *not all* are  $\uparrow\text{MON}$ ; *All* and *no* are  $\downarrow\text{MON}$ . There are also *non-monotonic* determiners; e.g., *exactly two* and *an even number of* are neither  $\text{MON}\uparrow$  nor  $\text{MON}\downarrow$ .

The characterization of veridical complements in terms of  $\text{MON}\uparrow$  corresponds nicely with the logical implication relations between (12,15a-c). An explanation for this behaviour is that the verb *see* restricts the extensions of verbal elements within its scope, and these verbal elements occur within the right-hand side argument of the determiners within the complement of *see*. Still one may wonder whether left monotonicity is important as well. This does not seem to be the case. E.g., (16a) has (16b) as a consequence, and (16c) (16d). But *every* is  $\downarrow\text{MON}$  and *most* is not left monotone.

- (16) a. At the party, John saw every student leave  
 b. At the party, every student left  
 c. At the party, John saw most students leave  
 d. At the party, most students left

Naked infinitive perception reports make plain that it is of considerable interest to extend quantifier theory to cover the many-valued case. As Van Eijck, this volume, shows, the extension involves providing suitable extensions of the principles EXT, CONS and ISOM, among many other things. See also Muskens 1989, and Langholm 1988.

### 3.4 Polyadic Quantification

In section 3.1, we have seen that a transitive sentence such as (17a) can be interpreted by *iterating* the noun phrases denotations as in (17b).

- (17) a. Every farmer bought a cow  
 b. **every**  $(\lambda x.Fx)(\lambda y.a(\lambda z.Cz)(\lambda z.Byz))$

Due to the work of Higginbotham and May 1981, Keenan 1987b, 1992, van Benthem 1989, Westerståhl 1994a it has become more and more apparent that not all sentence meanings can be obtained in the iterative way. In this section, we give some examples of such non-iterative forms of quantification; see Keenan 1987b, this volume, and Ben-Shalom 1994 for more examples.

#### 3.4.1 Cumulative Quantification

Cumulation is perhaps the simplest form of non-iterative quantification, and is first observed by Scha 1981. Sentence (18a) may be true if there are ten firms which each own twenty computers, as in (18b).

- (18) a. Ten firms own twenty computers  
 b.  $|\{f \in F : |\{c \in C : Ofc\}| = 20\}| = 10$   
 c.  $|\{f \in F : \exists c \in C Ofc\}| = 10 \ \& \ |\{c \in C : \exists f \in F Ofc\}| = 20$

But (18a) can also be used to state that ten firms own computers and that twenty computers are owned by firms. This is (18c), which leaves the numerals *ten* and *twenty* outside each others scope.

### 3.4.2 Branching Quantification

Branching, like cumulation, is a form of quantification where the scopes of the noun phrases remain independent. Following up on Hintikka 1974, Barwise 1979 studies sentences like (19a-c), which require branching of non-first-order quantifiers.

- (19) a. Most men and most women like each other  
 b. Few men and few women like each other  
 c. Four men and two women like each other

The meanings of (19a-c) are respectively given by (20a-c):

- (20) a.  $\exists XY[\mathbf{MMX} \wedge \mathbf{MWY} \wedge (X \times Y) \cap (M \times W) \subseteq R \cap (M \times W)]$   
 b.  $\exists XY[\mathbf{FMX} \wedge \mathbf{FWY} \wedge R \cap (M \times W) \subseteq (X \times Y) \cap (M \times W)]$   
 c.  $\exists XY[\mathbf{4MX} \wedge \mathbf{2WY} \wedge (X \times Y) \cap (M \times W) = R \cap (M \times W)]$

Notice that these meanings are not uniform across all determiners. The recipe in (20a) is intended for  $\text{MON}\uparrow$  and that in (20b) for  $\text{MON}\downarrow$  determiners (cf. Barwise 1979). Van Benthem introduced (20c) for non-monotone determiners. Westerståhl 1987 has a first proposal for a more general definition of branching. Cf. also Sher 1990, or Liu and Spaan, this volume.

Cumulation and branching are closely related; in each of the above cases branching implies cumulation. As Westerståhl 1987 observes, they are even equivalent for  $\text{MON}\downarrow$  determiners. A further observation is that the branching of non-monotone determiners is equivalent to cumulation *plus* the statement that  $R \cap A \times B$  is a cartesian product. The  $\text{MON}\uparrow$  case, however, is quite different. Then, cumulation and branching are still equivalent on cartesian products, but there is no statement in first-order logic with the  $\text{MON}\uparrow$  determiners added which defines the branching reading.

### 3.4.3 Reciprocals

Another form of polyadic quantification, which appears similar to branching, is used to give one of the several meanings of reciprocals. For instance, the prominent readings of (21a-c) are formally represented by means of (variants of) the so-called Ramsey quantifier in (22a-c). Cf. Dalrymple et al. 1994, Keenan and Westerståhl 1995.

- (21) a. Most men like each other  
 b. Few men like each other  
 c. Twelve men like each other

- (22) a.  $\exists X[\mathbf{MMX} \wedge (X \times X - \Delta(X)) \cap M \times M \subseteq R]$   
 b.  $\exists XY[\mathbf{FMXR} \cap M \times M \subseteq (X \times X - \Delta(X)) \cap M \times M]$   
 c.  $\exists XY[\mathbf{12MX} \wedge (X \times X - \Delta(X)) \cap M \times M = R \cap M \times M]$

Here,  $\Delta(X) := \{\langle d, d \rangle : d \in X\}$ . The use of  $\Delta$  ensures that in none of the cases the relevant men have to like themselves.

### 3.4.4 Resumptive Quantification

Explicit quantification can also be found outside noun phrases, in particular in adverbial modifiers. English has explicit adverbs of quantification which run over locations (*everywhere, somewhere, nowhere*), over periods of time (*always, sometimes, never*), and over states of affairs (*necessarily, possibly, impossibly*). Like noun phrase quantifiers, these standard adverbial quantifiers have non standard cousins: *often, seldom, at least five times, more than once, exactly twice*, and so on.

Adverbial quantifiers behave very much like noun phrase quantifiers, the main difference being their different domain of quantification. An exact specification of the domain of quantification can be difficult. Contextual information may be needed to determine whether an adverbial quantifier ranges over periods of time, events, or occasions, and to determine the ‘granularity’ of the domain of quantification. E.g., the fact that the temporal adverb in (23) ranges over days has to be inferred from the overall meaning of the sentence.

(23) Dinner is always served at six p.m. here

A very influential proposal for the treatment of adverbs of quantification is that of Lewis 1975. He argues that the adverb in (24a) quantifies over cases, which are identified with the tuples in a the relation  $\lambda xy.Mx \wedge Wy \wedge Lxy$ .

- (24) a. Mostly, a man loves a woman  
 b.  $M(\lambda xy.Mx \wedge Wy \wedge Lxy)$

Formally, this means that the quantifier *most* as it applies to sets has to be lifted so that it can take relational arguments. This can be done as follows (cf. Westerståhl 1989):

$$M_E^n R^n \Leftrightarrow M_{E^n} R^n$$

By this definition  $M^n$  is a property of  $n$  place relations, since

$$M_{E^n} \subseteq \wp(\underbrace{E \times \dots \times E}_{n \text{ times}})$$

It should be observed that the relational view on adverbs of quantification assumes that the indefinites *an N* are open expressions of form  $Nx$ . In particular, they are not quantifiers. This position is developed further in the discourse representation theory of Kamp 1981 and Heim 1982. Ladusaw, this volume, applies this approach to negative polarity items. Cf. also De Swart, this volume, for the issue of temporal expressions and quantification. In this volume, discussions of other linguistic issues can be found in van den Berg (quantifiers and anaphora), Hoeksema (exception phrases),

Lapierre (conditionals), de Mey (topic and focus) and Verkuyl and van der Does (plural noun phrases).

#### 4 Logical Issues

This part of the introduction aims to make the logical papers in this collection accessible to a larger audience. More in particular, it is intended for the reader who has some knowledge of EL (elementary logic, also known as first-order logic), and wants to have an overview of some key topics in the study of quantifier logics. We focus on two such topics:

- i) logics as an instrument of deduction,
- ii) logics as an instrument for the characterization of structures.

In the first case one would like to have nice proof systems which are sound and complete, and perhaps even decidable for the intended semantics. In the second case, one is rather more interested in the expressive power of a logic, and in its model-theoretic tools such as compactness and Löwenheim-Skolem-Tarski theorems. Using the notion of a quantifier as a recurrent theme, we give several examples of logics that combine (i) and (ii) in different ways. We will include proofs of most of the theorems we mention.

To present a logic as an instrument of deduction we use variants of analytic tableaux whenever possible (Smullyan 1968). In particular, section 4.1 introduces their application to so-called weak quantifier logic,  $EL^{wq}$ , which is EL with a quantifier ranging over an arbitrary set of sets added (Keisler 1970). The tableaux are obtained by adapting Anapolitanos and Väänänen 1981. A glimpse of logic as a tool to characterize structures is given in section 4.3, which has an overview of  $EL^q$ . This logic extends EL with an abstract real quantifier: a set of sets which is closed under permutations (Mostowski 1957, Thomason 1966). The results reported on here are mainly due to Yasuhara 1969. Next, we discuss some logics, which lie between  $EL^{wq}$  and  $EL^q$  (Doets 1991, Thomason and Johnson, jr. 1969). We also mention Lindstöm's results, which indicate what we can hope for in mediating between expressiveness and nice metaproperties. The section also discusses a decidable logic due, again, to Anapolitanos and Väänänen 1981.

In this section we concentrate on simple monadic quantifiers. Generalizing the results to binary or n-ary quantifiers is often straightforward. The important issue of polyadic quantification is presented in section 3. It is also a main theme in the overviews of Westerståhl 1989, Westerståhl 1995 and of Keenan and Westerståhl 1995.

##### 4.1 Weak Quantifier Logic

In his study of the quantifier 'there are uncountably many', Keisler 1970 was the first to consider the weak quantifier logic  $EL^{wq}$ . In this logic  $Q$

varies over arbitrary sets of sets which are not required to be permutation invariant. Strictly speaking, this makes  $Q$  a *qualifier* rather than a quantifier (but we retain the familiar way of speaking). It captures the general notion of a property of sets, but does not impose the further condition that this property should have to do with *size*. The main reason to study  $EL^{\mathbf{wq}}$  is that it has nice properties, which makes it suitable to approximate 'real' quantifier logics. Keisler 1970 already used this with great effect in his completeness theorem for 'there are uncountably many'. In his proof the intended model emerges as the limit of uncountably many weak ones. (Cf. also Van Lambalgen, this volume.)

As we will see below, weak quantifier logic is very closely related to first order logic. We will show that the proofs of the key metaproperties of first order logic (completeness, compactness, the Löwenheim-Skolem-Tarski property and undecidability) carry over in a straightforward fashion. This sketch may also serve as a brief rehearsal of the metatheory of first-order logic.

#### 4.1.1 Syntax, Semantics, Logical Consequence

A logic comes in three parts: a syntax which specifies its sentences, a semantics which specifies its models, and a satisfaction relation which specifies whether or not a sentence is true in a model.  $EL^{\mathbf{wq}}$  fits into this tripartition in the following way.

##### Syntax

The syntax of  $EL^{\mathbf{wq}}$  specifies the notion of a formula. The formulas of  $EL^{\mathbf{wq}}$  are given by the specification in (25).

$$(25) \quad \varphi ::= Rt_1 \dots t_n \mid \neg\varphi \mid \varphi \wedge \psi \mid \varphi \vee \psi \mid \varphi \rightarrow \psi \mid \exists x\varphi \mid \forall x\varphi \mid Qx\varphi$$

Here  $t_i$  is a variable or a constant. Call this language  $L$ . Note that  $L$  does not have identity statements or complex terms (terms built with function symbols). We left those out for reasons of simplicity. We say that  $\exists x$  in  $\exists x\varphi$  binds all free variables  $x$  in  $\varphi$ , and similarly for  $\forall x$  and  $Qx\varphi$ . A formula is a *sentence* iff it has no free variables. A *theory* is a set of sentences.

##### Semantics

Sentences speak about structures, which are sets  $E$  of elements standing in various relations to each other. Structures are turned into models  $\mathcal{M}$  by adding an interpretation function  $\llbracket - \rrbracket_a^{\mathcal{M}}$  ( $a$  an assignment;  $a : \text{VAR} \rightarrow E$ ). In this way the basic elements of a sentence are linked to truth-functions, or to objects obtained from the domain  $E$ :

- i)  $\llbracket \neg \rrbracket_a$ ,  $\llbracket \wedge \rrbracket_a$ ,  $\llbracket \vee \rrbracket_a$ ,  $\llbracket \rightarrow \rrbracket_a$  are the familiar functions from (pairs of) truth values to truth values;
- ii)  $\llbracket c \rrbracket_a$  is an element of  $E$ , and  $\llbracket x \rrbracket_a$  is the element  $a(x) \in E$ ;
- iii)  $\llbracket R^n \rrbracket_a$  is an  $n$ -place relation between elements of  $E$ ; and
- iv)  $\llbracket \exists \rrbracket_a = \{X \subseteq E; X \neq \emptyset\}$ ,  $\llbracket \forall \rrbracket_a = \{E\}$ , and  $\llbracket Q \rrbracket_a \subseteq \wp(E)$ .

Here and elsewhere the superscript  $\mathcal{M}$  is dropped if no confusion is likely, and so is the subscript  $a$ . Note that the quantifiers are treated as higher-order objects: they are sets of sets over the basic domain  $E$ . This is typical of the generalized quantifier view on logic.

### Satisfaction

The missing link between formulas and models is provided by the satisfaction relation. This relation defines the notion of a formula  $\varphi$  being true in a model  $\mathcal{M}$  under an assignment  $a$ , formally:  $\llbracket \varphi \rrbracket_a^{\mathcal{M}} = 1$ , or  $\mathcal{M} \models \varphi [a]$ . Let  $\circ \in \{\wedge, \vee, \rightarrow\}$ , and  $q \in \{\exists, \forall, Q\}$ . We define the function  $\llbracket \cdot \rrbracket_a^{\mathcal{M}} : L \rightarrow \{0, 1\}$  by recursion on the structure of  $\varphi$ , as follows:

- $\llbracket Rt_1 \dots t_n \rrbracket_a^{\mathcal{M}} = 1$  iff  $\langle \llbracket t_1 \rrbracket_a, \dots, \llbracket t_n \rrbracket_a \rangle \in [R]^{\mathcal{M}}$
- $\llbracket \neg \varphi \rrbracket_a^{\mathcal{M}} = 1$  iff  $\llbracket \neg \rrbracket(\llbracket \varphi \rrbracket_a^{\mathcal{M}}) = 1$
- $\llbracket \circ(\varphi, \psi) \rrbracket_a^{\mathcal{M}} = 1$  iff  $\llbracket \circ \rrbracket(\llbracket \varphi \rrbracket_a^{\mathcal{M}}, \llbracket \psi \rrbracket_a^{\mathcal{M}}) = 1$
- $\llbracket qx\varphi \rrbracket_a^{\mathcal{M}} = 1$  iff  $\widehat{x}.\llbracket \varphi \rrbracket_a^{\mathcal{M}} \in [q]_a$ .

Here,  $\widehat{x}.\llbracket \varphi \rrbracket_a^{\mathcal{M}} = \{d \in D : \llbracket \varphi \rrbracket_{a_x^d}^{\mathcal{M}} = 1\}$ , with  $a_x^d$  the assignment defined by:  $a_x^d(y) = d$  if  $y \equiv x$ ,  $a(y)$  otherwise.

The above satisfaction relation is defined *categorically*: each element in the language has a denotation of its own. Indeed, this semantics of  $\text{EL}^{\text{wq}}$  is compositional, in that the denotation of a sentence under an assignment is a function of the denotations of its compounds under that assignment and the way they are compounded. Also, the categorical treatment makes the type of object associated with a quantifier fully explicit, so that they become objects of study in themselves.

Usually the logical constants are treated *syncategorically*. Then, their contribution to the truth condition of a sentence is specified within the context of a formula, e.g.:

$$(26) \llbracket \exists x\varphi \rrbracket_a = 1 \Leftrightarrow \text{There is a } d \in E : \llbracket \varphi \rrbracket_{a_x^d} = 1$$

The two approaches are equivalent as far as satisfaction is concerned. The syncategorical view highlights that we quantify over the objects in  $E$  and not over the higher-order objects obtainable from  $E$ , such as:  $\wp(E)$ ,  $\wp(E) \times \wp(E)$ ,  $\wp(\wp(E) \times \wp(E))$ . For this reason  $\text{EL}^{\text{wq}}$  is called a first-order logic. The syncategorical approach is less suitable if the focus is on quantifier properties.

### Truth, Consequence, Expressiveness

Until now we have followed the Tarskian route of obtaining sentences as a special kind of formulas. Semantically this means that truth is a special case of satisfaction under an assignment. A sentence  $\sigma$  is true in a model  $\mathcal{M}$ ,  $\mathcal{M} \models \sigma$ , iff  $\sigma$  is satisfied in  $\mathcal{M}$  by some (hence: every) assignment. Besides truth, the following notions are important.

**Definition 4** A sentence is *satisfiable* iff it has a model. A sentence is *valid* iff it is true in all models. A sentence  $\sigma$  is a *logical consequence* of a set of sentences  $\Gamma$ ,  $\Gamma \models \sigma$ , iff for all  $\mathcal{M}$ : if  $\mathcal{M} \models \tau$  for all  $\tau \in \Gamma$ , then  $\mathcal{M} \models \sigma$ .

Observe that a sentence is a consequence of the empty set iff it is valid iff its negation is unsatisfiable.

Each sentence  $\sigma$  in  $\text{EL}^{\text{wq}}$  gives rise to the class of models in which it is true:  $\text{MOD}(\sigma) = \{\mathcal{M} : \mathcal{M} \models \sigma\}$ . When generalized to other logics, these classes provide a natural measure for expressive power.

**Definition 5** The logic  $L'$  is at least as expressive as the logic  $L$  ( $L \leq L'$ ) iff for each sentence  $\sigma$  in  $L$  there is a sentence  $\sigma'$  in  $L'$  such that

$$\text{MOD}_L(\sigma) = \text{MOD}_{L'}(\sigma')$$

$L$  and  $L'$  are as strong ( $L \equiv L'$ ) iff  $L \leq L'$  and  $L' \leq L$ .  $L'$  extends  $L$  iff  $L \leq L'$  and  $L \neq L'$ .

One way to prove that the logic  $L'$  extends the logic  $L$  is to give a sentence in  $L'$  with  $\text{MOD}_L(\sigma) \neq \text{MOD}_{L'}(\sigma')$ , for all  $\sigma$  in  $L$ . Another way is to show that  $L$  and  $L'$  do not share all properties. In the next section, which introduces tableaux for  $\text{EL}^{\text{wq}}$ , we come across some such properties.

#### 4.1.2 Tableaux

One of the aims of formalizing a logic is to study its properties in a precise way. For example, does the logic give a method to determine for each pair  $\langle \Gamma, \sigma \rangle$  whether  $\Gamma \models \sigma$ , and perhaps even whether  $\Gamma \not\models \sigma$ ? And are its sentences sensitive to the size of their models? In this section we shall quickly prove some of these properties for weak quantifier logic. We do so by means of semi-analytic tableaux, which are refinements of so-called Beth tableaux. Following up on work by Hintikka, Smullyan 1968 uses analytic tableaux to give elegant proofs of the completeness of EL besides some of its other metaproperties. In this section we extend his approach to  $\text{EL}^{\text{wq}}$  using insights from Anapolitanos and Väänänen 1981.

Now we view  $\text{EL}^{\text{wq}}$  as an instrument of deduction. We do so by presenting a tableau method which allows us to derive a conclusion  $\sigma$  from a set of premisses  $\Gamma$ , notation:  $\Gamma \vdash \sigma$ . Our first aim is to show that this syntactic relation coincides with logical consequence:

$$\Gamma \vdash \sigma \Leftrightarrow \Gamma \models \sigma$$

The proof of this result also gives some information on  $\text{EL}^{\text{wq}}$  as an instrument to characterize structures. For a start we concentrate on EL, but go on to show how the tableaux can be extended to  $\text{EL}^{\text{wq}}$ . Next we prove some important metaproperties of this logic.

#### Tableaux for First-Order Logic

Tableaux are constructed by means of rules which are formulated in terms

of signed sentences. Such sentences are of the form  $T\varphi$  and  $F\varphi$  with  $\varphi$  a sentence. The signs keep track of whether a sentence is true or false in a model:

$$\begin{aligned} \mathcal{M} \models T\varphi &\Leftrightarrow \mathcal{M} \models \varphi \\ \mathcal{M} \models F\varphi &\Leftrightarrow \mathcal{M} \not\models \varphi \end{aligned}$$

Signed sentences allow us to give a succinct formulation of the rules for constructing a tableau. These rules are based on a categorization of the sentences in  $\alpha$ 's (conjunctive),  $\beta$ 's (disjunctive),  $\gamma$ 's (universal), and  $\delta$ 's (existential). The details of this categorization are in (27).

$$(27) \quad \begin{array}{l} \alpha \quad T(\varphi \wedge \psi), F(\varphi \vee \psi), F(\varphi \rightarrow \psi), T\neg\varphi \\ \beta \quad T(\varphi \vee \psi), F(\varphi \wedge \psi), T(\varphi \rightarrow \psi), F\neg\varphi \\ \gamma \quad T\forall x\varphi, F\neg\exists x\varphi \\ \delta \quad T\exists x\varphi, F\neg\forall x\varphi \end{array}$$

The  $\alpha$ 's are conjunctive and the  $\beta$ 's disjunctive (modulo a little trick to subsume negations under these cases). In (28) we specify the signed con- and disjuncts for the different possibilities.

$$(28) \quad \begin{array}{|c|c|c|c|c|} \hline \alpha & \alpha_1 & \alpha_2 & \beta & \beta_1 & \beta_2 \\ \hline T(\varphi \wedge \psi) & T\varphi & T\psi & F(\varphi \wedge \psi) & F\varphi & F\psi \\ F(\varphi \vee \psi) & F\varphi & F\psi & T(\varphi \vee \psi) & T\varphi & T\psi \\ F(\varphi \rightarrow \psi) & T\varphi & F\psi & T(\varphi \rightarrow \psi) & F\varphi & T\psi \\ T\neg\varphi & F\varphi & F\varphi & F\neg\varphi & T\varphi & T\varphi \\ \hline \end{array}$$

As to the  $\delta$ 's and  $\gamma$ 's we define:

$$(29) \quad \begin{array}{|c|c|c|c|} \hline \gamma & \gamma(c) & \delta & \delta(c) \\ \hline T\forall x\varphi & T[c/x]\varphi & T\exists x\varphi & T[c/x]\varphi \\ F\exists x\varphi & F[c/x]\varphi & F\forall x\varphi & F[c/x]\varphi \\ \hline \end{array}$$

The above definitions ensure that relative to a model  $\mathcal{M}$  which has a name for each element we have:

- i)  $\mathcal{M} \models \alpha$  iff:  $\mathcal{M} \models \alpha_1$  and  $\mathcal{M} \models \alpha_2$
- ii)  $\mathcal{M} \models \beta$  iff:  $\mathcal{M} \models \beta_1$  or  $\mathcal{M} \models \beta_2$
- iii)  $\mathcal{M} \models \gamma$  iff:  $\mathcal{M} \models \gamma(c)$  for all  $c \in C$
- iv)  $\mathcal{M} \models \delta$  iff:  $\mathcal{M} \models \delta(c)$  for some  $c \in C$

Note that in case of such a model we can dispense with formulas and assignments in favour of sentences. The model has a constant  $c$  for each  $d$  in its domain with  $\llbracket c \rrbracket = d$ . If we write one of these constants as  $\underline{d}$ , the equivalence in (30) shows that sentences will do.

$$(30) \quad \mathcal{M} \models \varphi(x_1, \dots, x_n) [a] \Leftrightarrow \mathcal{M} \models \varphi(\underline{a(x_1)}, \dots, \underline{a(x_n)})$$

In what follows we will assume that every element has a name, unless stated otherwise.

Now we give rules to check the validity of a sentence. The idea is that if a sentence  $\sigma$  is valid its negation is unsatisfiable. So, one way to prove that  $\sigma$  is valid would be to show that it is impossible to construct a countermodel for  $\sigma$ ; i.e., a model for  $F\sigma$ . In attempting such a construction, we first place  $F\sigma$  at the root of a tree, and start building the tree by use of the rules A-D.

<b>A</b>	$\alpha$	<b>B</b>	$\beta$
	$\vdots$		$\vdots$
	$\alpha_1$		$\beta_1 \mid \beta_2$
	$\alpha_2$		
<b>C</b>	$\gamma$	<b>D</b>	$\delta$
	$\vdots$		$\vdots$
	$\gamma(c)$ for any $c$		$\delta(c)$ for a new $c$

The rules use the structure of a tree. In a tree the formulas above a certain formula—the formulas in between this formula and the root of the tree,—form a linear order. Rules A–D state that if the upper formula occurs somewhere on such a finite branch, it can be extended as indicated. E.g., in case of rule B the final node of the branch gets the two successors  $\beta_1$  and  $\beta_2$ .

**Definition 6** A *branch* in a tableau is a sequence of signed sentences which starts at the root of the tree and consists further of immediate successors. A *branch is closed* if there is a sentence  $\sigma$  such that both  $T\sigma$  and  $F\sigma$  are on it, otherwise it is open. A *tableau is closed* iff all of its branches are closed. It is *open* iff at least one of its branches is open.

In terms of open and closed tableaux we can define the notion of a proof.

**Definition 7** A sentence  $\sigma$  is *provable*,  $\vdash \sigma$ , iff there is a closed tableau with  $F\sigma$  at its root. A sentence  $\sigma$  is provable from a finite set of sentences  $\Gamma$  iff  $\vdash \bigwedge \Gamma \rightarrow \sigma$ . A sentence  $\sigma$  is provable from a set of sentences  $\Gamma$ ,  $\Gamma \vdash \sigma$ , iff there is a finite  $\Gamma_0 \subseteq \Gamma$  with  $\vdash \bigwedge \Gamma_0 \rightarrow \sigma$ .

For the moment we restricted ourselves to provability from finite sets of sentences.

**Tableaux for Weak Quantifier Logic**

To include rules for expressions of form  $Qx\varphi$  we supplement the categories  $\alpha, \beta, \gamma, \delta$  introduced in 27 with the new category  $\varepsilon$ .

(31)

$\varepsilon$	$\varepsilon(c)$
$\{FQx\varphi, TQy\psi\}$	$F([c/x]\varphi \leftrightarrow [c/y]\psi)$

Observe that  $\varepsilon$  is a pair of formulas. This is because we cannot draw an immediate consequence from a sentence  $Qx\varphi$ , as we can in the case of  $\forall x\varphi$ . Only in larger contexts such inferences are possible. To be more precise, whenever  $\mathcal{M} \models \{TQx\varphi, FQy\psi\}$  the sets  $\widehat{x}.\llbracket\varphi\rrbracket^{\mathcal{M}}$  and  $\widehat{y}.\llbracket\psi\rrbracket^{\mathcal{M}}$  cannot be identical. So, if  $\mathcal{M}$  has a name for each of its elements we can infer that there is a constant  $c$  such that  $\mathcal{M} \models F([c/x]\varphi \leftrightarrow [c/y]\psi)$ . For this reason we let  $\varepsilon$  vary over pairs of signed quantifier formulas, and define  $\varepsilon(c)$  accordingly. It also motivates rule E, which determines how to reason with such pairs.

$$\begin{array}{l} \mathbf{E} \quad \varepsilon \\ \quad \vdots \\ \quad \varepsilon(c) \quad \text{for a new constant } c \end{array}$$

Rule E states that if both elements of  $\varepsilon$  occur on a finite branch, it can be extended by appending  $\varepsilon(c)$ , where  $c$  does not occur on the tree. The notions of open and closed tableaux are changed to include rule E, but remain the same otherwise, and similarly for all other notions.

It should be observed that there is an important difference in the relation between  $\varepsilon$  and  $\varepsilon(c)$  on the one hand and, say,  $\gamma$  and  $\gamma(c)$  on the other. Whereas  $\gamma(c)$  can be considered a subformula of  $\gamma$ ,  $\varepsilon(c)$  is built from subformulas of the elements of  $\varepsilon$ . For this reason we speak of *semi-analytical* tableaux for  $\text{EL}^{\text{wq}}$ .

By way of example, here is a proof of  $Qx\varphi \vdash Qy[y/x]\varphi$  (with  $y$  free for  $x$  in  $\varphi$ ).

$$(32) \quad \begin{array}{l} F(Qx\varphi \rightarrow Qy[y/x]\varphi) \\ \quad TQx\varphi \\ \quad \quad FQy[y/x]\varphi \\ \quad \quad F([c/x]\varphi \leftrightarrow [c/y][y/x]\varphi) \\ \quad \quad \quad F[c/x]\varphi \quad | \quad F[c/y][y/x]\varphi \\ \quad \quad \quad T[c/y][y/x]\varphi \quad | \quad T[c/x]\varphi \end{array}$$

Because  $y$  is free for  $x$  in  $\varphi$ ,  $[c/y][y/x]\varphi$  is the same sentence as  $[c/x]\varphi$ . Therefore, tableau (32) is closed. Under the same proviso one proves that  $Qy[y/x]\varphi \vdash Qx\varphi$ . The combination of these two facts gives (33a).

$$(33) \quad \begin{array}{l} \text{a. } \vdash Qx\varphi \leftrightarrow Qy[y/x]\varphi \quad (y \text{ free for } x \text{ in } \varphi) \\ \text{b. } \vdash \forall x(\varphi \leftrightarrow \psi) \rightarrow (Qx\varphi \leftrightarrow Qx\psi) \end{array}$$

We leave it to the reader to show that (33b) holds as well. The theorems (33a,b) are introduced as axioms by Keisler 1970, who proved  $\text{EL}^{\text{wq}}$  to be sound and complete. We do the same but use adaptations of Smullyan 1968, and Anapolitanos and Väänänen 1981 for this purpose.

### 4.1.3 Metalogical Properties

In this section we prove that  $EL^{wq}$  is sound and complete, and that it has some other properties as well.

#### Soundness

A proof system should at least be *sound* (or *correct*). That is, we should be able to prove  $\sigma$  from  $\Gamma$  only if  $\sigma$  is a logical consequence of  $\Gamma$ :

$$\Gamma \vdash \sigma \Rightarrow \Gamma \models \sigma$$

The soundness of semi-analytic tableaux follows from Lemma 1.

**Lemma 1** *If there is a closed tableau with the signed sentence  $\sigma$  at its root, then  $\sigma$  is unsatisfiable.*

PROOF. Assume for a contradiction that  $\sigma$  has a closed tableau but is satisfiable. Since the set of sentences on a closed branch is unsatisfiable, it is enough to observe that the rules A–E preserve satisfiability.

- S.1 If the set  $S \cup \{\alpha\}$  is satisfiable, then so is  $S \cup \{\alpha, \alpha_1, \alpha_2\}$ .
- S.2 If the set  $S \cup \{\beta\}$  is satisfiable, then so is either  $S \cup \{\beta, \beta_1\}$  or  $S \cup \{\beta, \beta_2\}$ .
- S.3 If the set  $S \cup \{\gamma\}$  is satisfiable, then so is  $S \cup \{\gamma, \gamma(c)\}$  for *any*  $c$ .
- S.4 If the set  $S \cup \{\delta\}$  is satisfiable and  $c$  is a constant which does not occur in this set, then  $S \cup \{\delta, \delta(c)\}$  is satisfiable.
- S.5 If the set  $S \cup \{\varepsilon\}$  is satisfiable and  $c$  is a constant which does not occur in this set, then so is  $S \cup \{\varepsilon, \varepsilon(c)\}$ .

That S.1–3 are true is immediate. As to S.4, let  $\mathcal{M}$  be a model such that  $\mathcal{M} \models S \cup \{\delta\}$ . Since  $\delta$  is existential, there is a  $d \in E$  so that  $\mathcal{M} \models S \cup \{\delta(\underline{d})\}$ . Alter  $\mathcal{M}$  to  $\mathcal{M}^*$  by setting  $\llbracket c \rrbracket := d$ . The constant  $c$  does not occur in  $S \cup \{\delta\}$ , so we have  $\mathcal{M}^* \models S \cup \{\delta, \delta(c)\}$  as required.

As to S.5, let  $\varepsilon = \{FQx\varphi, TQy\psi\}$ , and let  $\mathcal{M}$  be a model for  $S \cup \varepsilon$ . This means that  $\hat{x}.\llbracket \varphi \rrbracket^{\mathcal{M}} \neq \hat{y}.\llbracket \psi \rrbracket^{\mathcal{M}}$ . There is a  $d \in E$  which is one of the sets but not in the other. Say,  $\mathcal{M} \models \llbracket \underline{d}/x \rrbracket \varphi$  and  $\mathcal{M} \not\models \llbracket \underline{d}/y \rrbracket \psi$ . We alter  $\mathcal{M}$  to  $\mathcal{M}^*$  by setting  $\llbracket c \rrbracket := d$ . Since  $c$  does not occur in  $S \cup \{\varepsilon\}$ , we conclude that  $\mathcal{M}^* \models S \cup \{\varepsilon, \varepsilon(c)\}$ .

Because  $\sigma$  is satisfiable and satisfiability is preserved under the rules A–E, each tableau with  $\sigma$  at its root should have at least one open branch. This contradicts that  $\sigma$  has a closed tableau.  $\square$

**Corollary 2** *The provability relation is sound:  $\Gamma \vdash \sigma \Rightarrow \Gamma \models \sigma$ .*

PROOF. Assume  $\Gamma \vdash \sigma$ . Then  $F(\bigwedge \Gamma \rightarrow \sigma)$  has a closed tableau. According to Lemma 1,  $F(\bigwedge \Gamma \rightarrow \sigma)$  has no model. This means that each model for  $\Gamma$  is a model for  $\sigma$ :  $\Gamma \models \sigma$ .  $\square$

We go on to show that the converse of Corollary 2 is also true: if  $\Gamma \models \sigma$  then  $\Gamma \vdash \sigma$ . This result is known as the completeness theorem.

### Completeness

A crucial step in proving the completeness theorem consists in proving the converse of Lemma 1, namely:

**Lemma 3** *If a signed sentence  $\sigma$  is unsatisfiable it has a closed tableau.*

The proof of Lemma 3, which is slightly more involved than that of Lemma 1, proceeds in two steps. First we define the notion of a *systematic* tableau, which has the property that each of its open branches yields a so-called Hintikka set (see below for a definition). Next we show that each Hintikka set has a model. This is sufficient, for if  $\sigma$  has no closed tableaux, then in particular all its systematic tableaux have an open branch. Since the sentences along such a branch form a Hintikka set, they have a model. But the branch starts with  $\sigma$ , so  $\sigma$  is satisfiable. Therefore, if  $\sigma$  is unsatisfiable, it should have at least one closed tableau.

The *systematic tableaux* are defined inductively: we first describe how to start, and then how to continue assuming that the previous step is completed. In order to have sufficiently many ‘fresh’ constants available, we add a countable infinite set  $C$  of new constants to our language.

The first step consists in placing the signed sentence whose satisfiability we are testing at the root of the tableau. Now assume that the  $n$ -th step is completed, and that the construction is not yet finished. Choose a non-atomic formula  $\sigma$  which is as close as possible to the root (i.e., all non-atomic formulas above it have been used). With every open branch  $\theta$  passing through this occurrence of  $\sigma$ , we do one of the following:

- a. If  $\sigma$  is an  $\alpha$  extend  $\theta$  by forming  $\theta \alpha_1 \alpha_2$  according to rule A;
- b. If  $\sigma$  is a  $\beta$ , branch at the end of  $\theta$  by simultaneously appending  $\beta_1$  and  $\beta_2$  as in rule B;
- c. If  $\sigma$  is a  $\gamma$  take the first constant  $c$  which does not occur on  $\theta$  and form  $\theta \gamma(c) \gamma$  as in rule C (note:  $\gamma$  is repeated!);
- d. If  $\sigma$  is a  $\delta$ , choose the first constant  $c$  which does not appear on the tree and form  $\theta \delta(c)$  according to rule D.
- e. If  $\sigma$  is of the form  $TQx.\varphi$  add to  $\theta$  the formula  $F([c/x]\varphi \leftrightarrow [c/y]\psi)$ ,  $c$  a new constant, for all  $FQy.\psi$  above  $TQx.\varphi$  (the case  $\sigma \equiv FQx.\varphi$  is similar).

Next we mark  $\sigma$  as used, and check (i) whether the tableau is closed and (ii) whether all non-atomic signed sentences have been used. If both (i) and (ii) hold, the construction halts, otherwise we repeat the above construction step. A systematic tableau is *finished* if it is infinite or if it cannot be continued by means of the above recipe. To say a bit more about open tableau branches we need the following definition.

**Definition 8** A set  $S$  of signed formulas is a *Hintikka set* for a set of constants  $C$  iff:

- H.1 For no  $\sigma$  both  $T\sigma$  and  $F\sigma$  are in  $S$ .  
 H.2 If  $\alpha \in S$ , then  $\alpha_1 \in S$  and  $\alpha_2 \in S$ .  
 H.3 If  $\beta \in S$ , then  $\beta_1 \in S$  or  $\beta_2 \in S$ .  
 H.4 If  $\gamma \in S$ , then  $\gamma(c) \in S$  for all  $c \in C$ .  
 H.5 If  $\delta \in S$ , then  $\delta(c) \in S$  for a  $c \in C$ .  
 H.6 If  $\varepsilon \in S$ , then  $\varepsilon(c) \in S$  for a  $c \in C$ .

It is not difficult to see that the set of formulas occurring at the open branch of a systematic tableau is a Hintikka set.

Hintikka sets always have a model. This means that constructing a systematic tableau serves the purpose it was designed for: the formula at its root occurs on every open branch, hence it is satisfiable.

**Lemma 4** (Hintikka's lemma) *Each Hintikka set for a denumerable set of constants  $C$  has a denumerable model.*

PROOF. Let  $S$  be a Hintikka set for set of constants  $C$ . Assume  $C$  is denumerable. We have to find a denumerable model  $\mathcal{M}$  with

$$T\varphi \in S \Rightarrow \mathcal{M} \models \varphi \Rightarrow F\varphi \notin S \quad (*)$$

for all  $\varphi$  of the language. Such a model can be defined as follows. As its universe we take the denumerable set  $C$  of constants. This choice ensures that  $\mathcal{M}$  is denumerable.

In defining the interpretation function, the following stipulations will prove useful:

$$\begin{aligned} \hat{x}.\llbracket\varphi\rrbracket^T &:= \{c \in C \mid T[c/x]\varphi \in S\} \\ \hat{x}.\llbracket\varphi\rrbracket &:= \{c \in C \mid \mathcal{M} \models [c/x]\varphi\} \\ \hat{x}.\llbracket\varphi\rrbracket^F &:= \{c \in C \mid F[c/x]\varphi \notin S\}. \end{aligned}$$

The interpretation function  $\llbracket-\rrbracket$  is now defined by:

1.  $\llbracket c \rrbracket := c$
2.  $\llbracket R^n \rrbracket := \{\langle c_1, \dots, c_n \rangle \mid TRc_1 \dots c_n \in S\}$
3.  $\llbracket Q \rrbracket := \{X \subseteq C \mid \exists A \in S : A \equiv TQx\varphi \ \& \ \hat{x}.\llbracket\varphi\rrbracket^T \subseteq X \subseteq \hat{x}.\llbracket\varphi\rrbracket^F\}$ .

It remains to be established that  $\mathcal{M}$  has property (\*). We only give the cases for atomic sentences and for sentences of form  $Qx\varphi$ ; the others are immediate from the induction hypothesis.

That  $\mathcal{M} \models Rc_1, \dots, c_n$  in case  $TRc_1, \dots, c_n \in S$  is clear. So assume that  $FRc_1, \dots, c_n \in S$ . Then by  $H_1$ ,  $TRc_1, \dots, c_n \notin S$ . So  $\langle c_1, \dots, c_n \rangle \notin \llbracket R \rrbracket$ , and therefore  $\mathcal{M} \not\models Rc_1, \dots, c_n$ .

As to quantified sentences, assume that  $TQx\varphi \in S$ . By the induction hypothesis:  $\hat{x}.\llbracket\varphi\rrbracket^T \subseteq \hat{x}.\llbracket\varphi\rrbracket \subseteq \hat{x}.\llbracket\varphi\rrbracket^F$ . So  $\hat{x}.\llbracket\varphi\rrbracket \in \llbracket Q \rrbracket$  and  $\mathcal{M} \models Qx\varphi$ . Conversely, assume that  $FQx\varphi \in S$ . Suppose for a contradiction that  $\mathcal{M} \models Qx\varphi$ . Then  $\hat{x}.\llbracket\varphi\rrbracket \in \llbracket Q \rrbracket$ . By definition, there are  $y, \psi$  such that  $TQy\psi \in S$ , and

$$(i) \hat{y}.\llbracket\psi\rrbracket^T \subseteq \hat{x}.\llbracket\varphi\rrbracket \subseteq \hat{y}.\llbracket\psi\rrbracket^F.$$

Since  $\{FQx\varphi, TQy\psi\} \subseteq S$ , there is a  $c \in C$  with  $F([c/x]\varphi \leftrightarrow [c/y]\psi) \in S$ . It follows that either  $a$  or  $b$  holds:

- a.  $T[c/y]\psi, F[c/x]\varphi \in S$
- b.  $T[c/x]\varphi, F[c/y]\psi \in S$

If  $a$ , then  $c \in \hat{y}.\llbracket\psi\rrbracket^T$  and hence by (i)  $c \in \hat{x}.\llbracket\varphi\rrbracket$ . By the induction hypothesis for  $\varphi$ ,  $c \in \hat{x}.\llbracket\varphi\rrbracket^F$ , which contradicts  $F[c/x]\varphi \in S$ . So  $b$  must hold. But then  $c \in \hat{x}.\llbracket\varphi\rrbracket^T$ , and hence by the induction hypothesis for  $\varphi$ :  $c \in \hat{x}.\llbracket\varphi\rrbracket$ . By (i),  $c \in \hat{y}.\llbracket\psi\rrbracket^F$ , which contradicts  $F[c/y]\psi \in S$ . We conclude that  $\mathcal{M} \not\models Qx\varphi$ .  $\square$

The above lemmas have some important consequences.

**Theorem 5** (Completeness) *Provability and logical consequence are equivalent:*

$$\Gamma \models \sigma \Leftrightarrow \Gamma \vdash \sigma$$

PROOF. With a view to Lemma 2, we only have to prove that  $\Gamma \models \sigma$  implies  $\Gamma \vdash \sigma$ . So assume  $\Gamma \not\vdash \sigma$ . Each tableau with  $F(\bigwedge \Gamma \rightarrow \sigma)$  at its root is open. Choose an open branch of a systematic tableaux with this property. The formulas on this branch form a Hintikka set, and hence have a model. This model is a countermodel to  $\Gamma \models \sigma$ .  $\square$

In fact theorem 5 also holds for infinite  $\Gamma$ . For simplicity assume that  $\Gamma$  is a countably infinite set of sentences enumerated by:  $\gamma_1, \dots, \gamma_n, \dots$ . We have to ensure that the Hintikka set used in the proof of theorem 5 contains  $\Gamma$ . But this is simple. Before completing the  $n$ -th step in the construction of a systematic tableau, just add  $\gamma_n$  to all its open branches.

We finish this section with some further important consequences of Hintikka's lemma.

### Other Metaproperties

When viewing  $EL^{wq}$  as an instrument to characterize structures, the next three results are basic.

**Theorem 6** (Downward Löwenheim-Skolem-Tarski) *If  $\Gamma$  has an infinite model, it has a denumerable model.*

PROOF. Suppose  $\Gamma$  has an infinite model  $\mathcal{M}$  and assume that  $\mathcal{M}$  is uncountable. Let  $C$  be an infinite denumerable set of constants and let  $L$  be a language of weak quantifier logic based on  $C$  and appropriate for  $\mathcal{M}$  (in the sense that  $L$  has relation symbols for all relations of  $\mathcal{M}$ ). Let  $\sigma$  range over sentences of  $L$ . Then the set  $H$  given below is a Hintikka set for  $C$ :

$$H := \{T\sigma : \mathcal{M} \models \sigma\} \cup \{F\sigma : \mathcal{M} \not\models \sigma\}$$

By Hintikka's lemma H has a denumerable model, which is also a model for  $\Gamma$ .  $\square$

**Theorem 7** (Compactness) *If each finite subset of a theory  $\Gamma$  has a model then  $\Gamma$  has a model.*

PROOF. Suppose that  $\Gamma$  does not have a model. Then  $\Gamma \models \perp$ , for some contradiction  $\perp$ . By completeness:  $\Gamma \vdash \perp$ , so there is a finite  $\Gamma_0 \subseteq \Gamma$  with:  $\Gamma_0 \vdash \perp$ . Since  $\text{EL}^{\text{wq}}$  is sound,  $\Gamma_0$  does not have a model.  $\square$

**Theorem 8** (Upward Löwenheim-Skolem-Tarski) *If a theory  $\Gamma$  has an infinite model of cardinality  $\kappa$ , it has models for all cardinalities larger than  $\kappa$  as well.*

PROOF. Let  $\lambda$  be a cardinal larger than  $\kappa$ , and let  $C$  be a set of new constants of size  $\lambda$ . Consider the theory:

$$\Lambda := \Gamma \cup \{c_i \neq c_j : i, j < \lambda \text{ and } i \neq j\}$$

Each finite  $\Lambda_0 \subseteq \Lambda$  contains at most finitely many constants from  $C$ , say  $c_1 \dots c_n$ . Since  $\Gamma$  has an infinite model  $\mathcal{M}$  we can find  $d_1 \dots d_n$  such that  $\langle \mathcal{M}, d_1 \dots d_n \rangle \models \Lambda_0$ . By compactness  $\Lambda$  has a model. As in the proof of downward LST, this model yields a Hintikka set for  $C$ . A check of Hintikka's lemma now shows that  $\Lambda$  has a model of size  $|C| = \lambda$ .  $\square$

It follows immediately from the fact that upward LST holds for first order logic and for weak quantifier logic, that these logics cannot define the structure of the natural numbers. No first order theory (or weak quantifier logic theory)  $\Gamma$  can provide a definition, for all these theories also have models that are 'too large'.

It should be noted that the reasoning to establish these metaproperties of  $\text{EL}^{\text{wq}}$  is almost the same as for  $\text{EL}$ . Adding a weak quantifier to first-order logic does hardly change a thing.

Doets, this volume, proves interpolation for  $\text{EL}^{\text{wq}}$ . Moreover, he shows that the formulas in this logic which are preserved under homomorphisms are exactly the positive ones. Cf. his paper for details.

A property which  $\text{EL}$  and  $\text{EL}^{\text{wq}}$  both lack is *decidability*: there is no mechanical way to compute whether  $\models \sigma$  or  $\not\models \sigma$ . Yet, tableaux do have a 'machine' to *enumerate* all valid sentences. To see this, let  $\sigma_1, \dots, \sigma_n, \dots$  be an enumeration of all sentences. The first action of the machine consists in placing  $F\sigma_1$  at the root of a systematic tableau  $T_1$ . If the tableaux  $T_1, \dots, T_n$  are available, it makes a step in each of them, and checks whether or not they are closed. In case  $T_i$  is closed, the machine appends  $\sigma_i$  to the enumeration of valid sentences and removes  $T_i$  from the list of tableaux. When all available tableaux have been checked, it starts  $T_{n+1}$  with  $F\sigma_{n+1}$ . Clearly this gives an effective (or: recursive) enumeration of all sentences  $\sigma$  with  $\models \sigma$ . So if a sentence is valid, this can be determined in a finite

number of steps. The logician Church has shown that there is no machine to enumerate the invalid sentences. Notice that for this reason  $\text{EL}^{\text{wq}}$  is undecidable. Such a machine would enable us to decide whether or not a sentence is valid after all. Simply let both machines run and check in whose output the sentence occurs. This test halts in finitely many steps.

The next section uses compactness and the LST theorems to give an indication of the expressive power of EL (we forget about  $Q$  for the moment).

## 4.2 Intermezzo: First-order Logic

### 4.2.1 First-order Definable Quantifiers

The present formulation of EL interprets quantifiers as properties of sets. However, in natural language quantifiers often appear as relations between sets. E.g., in stating that ‘some man walks’ we claim that the men and the walkers are not disjoint. As is well-known, EL can use its connectives to define the relational version of ‘some’:

$$(34) \text{[some]}_E[\mathbf{A}][\mathbf{B}] \Leftrightarrow \langle E, [\mathbf{A}], [\mathbf{B}] \rangle \models \exists x(Ax \wedge Bx)$$

for each  $E$ . More in general we say that a two-place determiner  $\mathbf{D}$  is definable in the language of the two one place predicates  $A$  and  $B$  iff there is a sentence  $\varphi(A, B)$  with for all  $E$ :

$$(35) \text{[D]}_E[\mathbf{A}][\mathbf{B}] \Leftrightarrow \langle E, [\mathbf{A}], [\mathbf{B}] \rangle \models \varphi(A, B)$$

We now give an impression of the quantifiers which are first-order definable, but also of show of some that they are not.

Plainly, EL defines such quantifiers as *some A*, *all A*, *no A*, and *not all A*:

$$(36) \begin{array}{ll} \text{some } AB & \equiv \exists x(Ax \wedge Bx) \\ \text{no } AB & \equiv \neg \exists x(Ax \wedge Bx) \\ \text{not all } AB & \equiv \exists x(Ax \wedge \neg Bx) \\ \text{all } AB & \equiv \neg \exists x(Ax \wedge \neg Bx) \end{array}$$

These quantifiers are given in terms of  $\neg$ ,  $\wedge$ , and  $\exists$ . If we add the identity sign ‘=’, it is also possible to define the numerical expressions *at least n A*:

$$(37) \begin{array}{ll} \text{at least 1 } AB & \equiv \exists x(Ax \wedge Bx) \\ \text{at least } n + 1 \text{ } AB & \equiv \exists x[Ax \wedge Bx \wedge \\ & \text{at least } n \text{ } (\lambda y.(y \neq x \wedge Ay))(\lambda y.By)] \end{array}$$

This recursive definition is based on the idea that, e.g., *at least three A are B* is equivalent to: *There is an A which is a B and at least two other A are also B*. Using the same distribution of negation as in (36), we get *less than*

$n$   $A$  are  $B$ , at least  $n$   $A$  are not  $B$  and less than  $n$   $A$  are not  $B$ . Moreover, we have:

$$(38) \quad \begin{array}{ll} \text{at most } n \text{ } AB & \equiv \text{less than } n + 1 \text{ } AB \\ \text{between } n \text{ and } m \text{ } AB & \equiv \text{at least } n \text{ } AB \wedge \text{at most } m \text{ } AB \\ \text{exactly } n \text{ } AB & \equiv \text{between } n \text{ and } n \text{ } AB. \end{array}$$

Restricting ourselves to models with a finite domain, we can fully describe what is possible within EL. It is shown in van Benthem 1984 and Westerståhl 1984 that on finite models all first-order definable quantifiers  $\mathbf{D}(\lambda x.Ax)(\lambda x.Bx)$  are disjunctions of conjunctions of the form:

$$(39) \quad \begin{array}{l} \text{between } k \text{ and } k + 1 \text{ } (\lambda x.Ax)(\lambda x.Bx) \wedge \\ \text{between } n \text{ and } m \text{ } (\lambda x.Ax)(\lambda x.\neg Bx) \end{array}$$

#### 4.2.2 Non-first-order Definable Quantifiers

Not all quantifiers are first-order definable. Perhaps the simplest examples to show this are the cardinality quantifiers  $\mathbf{Q}^\kappa$ :

$$\mathbf{Q}_E^\kappa X \Leftrightarrow |X| \geq \kappa$$

with  $\kappa$  an uncountable cardinal. The sentence  $Q^\kappa x.x = x$  has the infinite model  $\langle \kappa \rangle$  but lacks a countable one, so by downward LST it cannot be first-order definable. Indeed, EL discerns each finite cardinal but no infinite ones. In a sense, the situation is reversed as to the general concepts of ‘finite’ and ‘infinite’. There are sets of first-order sentences (but no finite sets!) which only have infinite models. For instance,

$$(40) \quad \Delta_C := \{c \neq d : c, d \text{ different elements of } C\}$$

with  $C$  a countably infinite set of constants. But, as we shall see, there are no first-order theories with just finite models.

Another example of a non-first order-definable quantifier is the Rescher-quantifier  $\mathbf{R}$ . On its intended meaning  $Rx.\varphi$  states that most things have  $\varphi$ :

$$\mathbf{R}_E X \Leftrightarrow |X| > |E - X|$$

A standard application of the compactness theorem and downward LST shows that EL cannot define  $\mathbf{R}$ .

**Theorem 9** *The quantifier  $\mathbf{R}$  is not first-order definable.*

PROOF. Suppose for a contradiction that  $Rx.Ax$  is first-order definable, say by  $\psi^{\mathbf{r}}(A)$ . Now consider the theory:

$$\Gamma^{\mathbf{r}} := \Delta_{C \cup D} \cup \{Ac_i : i \in \omega\} \cup \{\neg Ad_j : j \in \omega\} \cup \{\psi^{\mathbf{r}}(A)\}$$

with  $C, D$  disjoint countably infinite sets of constants, and with  $\Delta_{C \cup D}$  as in (40). Let  $\Gamma^* \subseteq \Gamma^{\mathbf{r}}$  be finite, say:

$$\begin{aligned} \Gamma^* &= \{Ac_1, \dots, Ac_n\} \cup \{\neg Ad_1, \dots, \neg Ad_m\} \cup \\ &\quad \cup \Delta_{\{c_1, \dots, c_n, d_1, \dots, d_m\}} \cup \{\psi^{\mathbf{r}}(A)\} \end{aligned}$$

Assume  $m > n$  (the other case is similar). Take  $E$  with  $|E| = 2m + 1$  and  $A \subseteq E$  with  $|A| = m + 1$ , and interpret the constants accordingly. Then  $\langle E, A \rangle \models \Gamma^*$ . This means that each finite part of  $\Gamma^{\mathbf{r}}$  has a model, and thus, by compactness,  $\Gamma^{\mathbf{r}}$  has a model. Downward LST gives a countable model  $\mathcal{M} \models \Gamma^{\mathbf{r}}$ . In  $\mathcal{M}$ ,  $|A| = |E - A| = |\omega|$ , but also  $\mathcal{M} \models \psi^{\mathbf{r}}(A)$ . This contradicts the assumption that  $\psi^{\mathbf{r}}(A)$  defines  $R$ .  $\square$

Along similar lines we can prove, e.g., that the quantifier **finitely many**, and hence **infinitely many**, is not definable within EL. The proof is like that of theorem 9 but uses the theory  $\Gamma^{\mathbf{f}}$  instead.

$$\Gamma^{\mathbf{f}} := \{\psi^{\mathbf{f}}(A)\} \cup \{Ac : c \in C\} \cup \Delta_C$$

We have already indicated that the *set* of sentences  $\{Ac : c \in C\} \cup \Delta_C$  defines **infinitely many**. However, this wider concept of definability still leaves **R** and **finitely many** outside the scope of EL. By the above reasoning both  $\Gamma^{\mathbf{r}}$  and  $\Gamma^{\mathbf{f}}$  have models which do not comply with these quantifiers. Notice, by the way, that these non-definability arguments also go through for  $\text{EL}^{\text{wq}}$ .

### 4.2.3 Finitism

The previous discussion may give the impression that EL is a weak logic in some absolute sense, which is hence of limited use. This impression would be incorrect. First, there are many areas in which the apparent limitations of EL are in fact very useful. First-order non-standard models are a powerful tool in the study of arithmetic, analysis, and set-theory. Moreover, there is a hidden parameter in our discussion of EL's expressive power, in that the class of models is unlimited. For certain subjects this is too liberal. For instance, the relational databases of computer science are much like models, but are all finite. And in the study of natural language quantification one often finds the same restriction.

On the class of finite models EL can define some important finitistic notions. But in this area its model theory looks very different. On the finite models EL loses many of the metaproperties which we encountered above.

- i) Relative to finite models EL is incomplete.
- ii) EL has no upward LST analogue for finite cardinals. There is no  $n$  such that  $\varphi$  has a model of size  $n$  only if it has models of size  $m$ ,  $m > n$ .
- iii) EL has no downward LST analogue for finite cardinals. There is no  $n$  such that if  $\varphi$  has a model of size  $m$ ,  $m > n$ , it has a model of size  $n$ .
- iv) Relative to finite models EL is no longer compact.

Fact (i) was proved in Trahtenbrot 1950 by recursion-theoretic means. Facts (ii–iii) are immediate since EL can define the class of models with

a domain of size  $n$ . Loss of compactness remains. Here there are some options. First, ‘compact’ could mean, as before, that if each finite part of  $\Gamma$  has a finite model so has  $\Gamma$ . This is false for finitistic EL, as is show by the theory  $\{‘there\ are\ n\ things’ : n \in \omega\}$ . Second, ‘compact’ could mean that if all  $\gamma \in \Gamma$  have a finite model so has  $\Gamma$ . This is refuted by a finite counterexample.

$$\{\forall x \neg Rxx, \forall xyz(Rxy \wedge Ryz \rightarrow Rxz), \forall x \exists y.Rxy\}$$

Clearly, there are finite irreflexive relations, finite transitive relations, and finite relations with a successor for each element in its domain. But if a relation is to satisfy all three requirements it can only be infinite. (An irreflexive, transitive relation allows no finite cycles.) To get a taste of the issues involved in finite model theory we refer to Gurevich 1985.

There are logics which show a similar pattern on the class of all models as EL does on the finite ones: expressive but with few model theoretic tools. Still, logics more expressive than EL, or  $EL^{wq}$  for that matter, are useful, in mathematics as well as in linguistics. Perhaps the simplest way to obtain such logics is to enrich EL with real quantifiers that correspond to non-first-order properties of sets. The next section has examples of such logics.

### 4.3 Quantifier Logics

In defining  $EL^{wq}$  we interpreted  $Q$  as an set of subsets of the universe  $E$ . We also saw that the quantifier  $\exists$  got interpreted as the set of *non-empty* subsets of the universe, and the quantifier  $\forall$  as the set containing only the universe. The property of being a non-empty set and the property of coinciding with the whole universe are not arbitrary properties, so the interpretation of  $Q$  is indeed too weak. As we have seen in connection with the ISOM constraint in Section 3.2, the defining property for a quantifier should have something to do with quantity.

In Section 3, we focussed on binary (or restricted) quantifiers, here we will consider unary (unrestricted) quantifiers. Let us first see which insights from Section 3 carry over to the unary case, if we consider a unary quantifier  $Q$  on universe  $E$  as a binary quantifier with restriction set  $E$ . First note that the constraint UNIV, which combines EXT and CONS, becomes trivial, for we have indeed for all  $B \subseteq E : Q_E(E, B) \Leftrightarrow Q_E(E, E \cap B)$ . The constraint ISOM now takes the following shape (writing the universe of quantification as a subscript):

**ISOM** If  $\pi$  is a bijection from  $E$  to  $E'$ , then  $Q_E B \Leftrightarrow Q_{E'} \pi[B]$ .

This very idea was captured in Mostowski 1957 by means of the following definition.

**Definition 9** A quantifier  $Q$  is a functor such that for all domains  $E, E'$ :

- i)  $\mathbf{Q}_E \subseteq \wp(E)$   
 ii)  $\mathbf{Q}_E(X) \Leftrightarrow \mathbf{Q}_{E'}(\pi[X])$ , for all  $X \subseteq E$ , and all bijections  $\pi : E \rightarrow E'$ .

In (41) we give some examples of unary quantifiers.

$$\begin{aligned}
 (41) \quad & \top_E = \wp(E) \\
 & \mathbf{all}_E = \{E\} \\
 & \mathbf{no}_E = \{\emptyset\} \\
 & \mathbf{not all}_E = \{X \subseteq E : X \neq E\} \\
 & \mathbf{at least } n_E = \{X \subseteq E : |X| \geq n\} \\
 & \mathbf{exactly } n_E = \{X \subseteq E : |X| = n\} \\
 & \mathbf{at most } n_E = \{X \subseteq E : |X| \leq n\} \\
 & \mathbf{between } n \mathbf{ and } m_E = \{X \subseteq E : n \leq |X| \leq m\} \\
 & \mathbf{most things}_E = \{X \subseteq E : |X| > |E - X|\} \\
 & \mathbf{less than half of the}_E = \{X \subseteq E : |X| \leq |E - X|\} \\
 & \mathbf{an even number of}_E = \{X \subseteq E : \exists n (|X| = 2n)\} \\
 & \mathbf{finitely many}_E = \{X \subseteq E : \exists n (|X| = n)\} \\
 & \mathbf{infinitely many}_E = \{X \subseteq E : |X| \geq \aleph_0\} \\
 & \mathbf{uncountably many}_E = \{X \subseteq E : |X| \geq \aleph_1\} \\
 & \perp_E = \emptyset
 \end{aligned}$$

It is not hard to see that the examples in (41) are all quantifiers in the sense of Mostowski. Each of these quantifiers  $\mathbf{Q}$  gives rise to a logic  $\text{EL}(\mathbf{Q})$ . By adding an indexed set  $Q_i$  of quantifiers to  $\text{EL}$ , we obtain an extension  $\text{EL}(Q_i)_{i \in I}$ .

We have already seen that for some of the  $\mathbf{Q}$ 's in (41) the logic  $\text{EL}(\mathbf{Q})$  is more expressive than weak quantifier logic, because  $\text{EL}^{\text{wq}}$  cannot define  $\mathbf{Q}$ . E.g., **finitely many** was such. This illustrates, by the way, that first-order definability has nothing to do with the general concept of a quantifier.

There is an alternative way to capture the idea that quantifiers should be insensitive to particular individuals. Relative to a domain  $E$ , the sets  $X$  and  $Y$  are *strongly equal*,  $X \equiv Y$ , iff  $|X| = |Y|$  and  $|E - X| = |E - Y|$ . Notice that only on finite domains strong equality is identical to equicardinality! For example, the natural numbers have the same cardinality as the even numbers. But relative to the natural numbers these sets are not strongly equal. On a domain  $E$  the quantifiers can now be characterized as those sets of sets which do not discern between strongly equal sets. Proposition 10 generalizes this characterization across universes.

**Proposition 10** *A functor  $\mathbf{Q}$  such that for all  $E$   $\mathbf{Q}_E \subseteq \wp(E)$  is a quantifier iff for all  $E, E'$  and all  $X \subseteq E, Y \subseteq E'$  with  $|X| = |Y|$  and  $|E - X| = |E' - Y|$ :*

$$\mathbf{Q}_E(X) \Leftrightarrow \mathbf{Q}_{E'}(Y)$$

PROOF.  $[\Rightarrow]$  Suppose  $\mathbf{Q}$  is a quantifier and  $|X| = |Y|$  and  $|E - X| =$

$|E' - Y|$ . Then the injections given by the identities can be joined to give a bijection  $\pi : E \rightarrow E'$ . Since  $\mathbf{Q}$  is a quantifier and  $\pi(X) = Y$ , we have:  $\mathbf{Q}_E(X) \Leftrightarrow \mathbf{Q}_{E'}(Y)$ . [ $\Leftarrow$ :] This is immediate, since for each bijection  $\pi : E \rightarrow E'$  we have  $|X| = |\pi(X)|$  and  $|E - X| = |E' - \pi(X)|$  for all  $X \subseteq E$ .  $\square$

Proposition 10 says that the truth of a statement  $\mathbf{Q}_E(X)$  depends entirely on the cardinalities  $|X|$  and  $|E - X|$  (not just  $|X|!$ ). On top of this Mostowski 1957 notes that a quantifier  $\mathbf{Q}_E$  can be represented as a two place relation  $\mathbf{T}^{\mathbf{Q}_E}$  between cardinals  $\mu, \kappa$  with  $\mu + \kappa = |E|$ . More in particular, one defines  $\mathbf{T}^{\mathbf{Q}}$  and  $\mathbf{Q}^{\mathbf{T}}$  by:

$$(42) \quad \begin{aligned} \mathbf{T}_E^{\mathbf{Q}}(n, m) &\Leftrightarrow \exists X[\mathbf{Q}_E(X) \wedge |E - X| = n \wedge |X| = m] \\ \mathbf{Q}_E^{\mathbf{T}}(X) &\Leftrightarrow \mathbf{T}_E(|E - X|, |X|) \end{aligned}$$

for all  $E$ . That these views are indeed equivalent boils down to showing that converting a quantifier into a relation and then back into a quantifier yields nothing new, and that the same holds for the converse process:

$$(43) \quad \mathbf{Q} = \mathbf{Q}^{\mathbf{T}^{\mathbf{Q}}} \quad \text{and} \quad \mathbf{T} = \mathbf{T}^{\mathbf{Q}^{\mathbf{T}}}$$

### 4.3.1 The Tree of Numbers

Restricting our attention to finite domains, the quantifiers become subsets of the plane  $\mathbb{N}^2$  which can be visualized as a number tree. In figure 7, we give the general format of this tree.

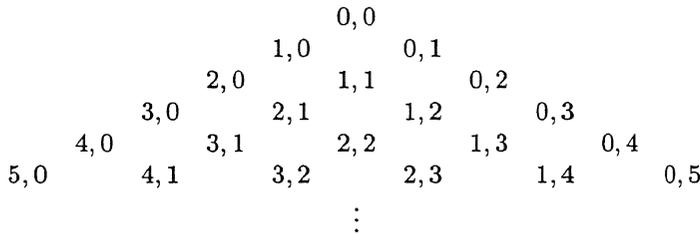

FIGURE 7 General Format of a Numerical Tree

If  $(i, j)$  is a number pair in the tree for  $\mathbf{Q}$ , then  $i + j$  is the cardinality of the universe  $E$ ,  $i$  is the cardinality of  $E - X$ , and  $j$  is the cardinality of  $X$ . Note that the same kind of representation also works for binary quantifiers satisfying EXT, CONS and ISOM, for here we can take  $i$  to be the cardinality of  $A - B$ , where  $A$  is the first and  $B$  the second argument of the quantifier, and  $j$  the cardinality of  $A \cap B$ . (Thanks to EXT and CONS we can define a unary quantifier  $\mathbf{Q}'$  so that:  $\mathbf{Q}'_A A \cap B \Leftrightarrow \mathbf{Q}_E AB$ .)

A sequence  $(r, i)$  for a certain  $r \in \mathbb{N}$  is called a 'row', and a sequence  $(j, c)$  for a certain  $c \in \mathbb{N}$  is called a 'column'. The diagonal  $n$ , which

consists of the pairs  $(i, j)$  with  $i + j = n$ , corresponds to the domains of size  $n$ . If a pair  $(|E - X|, |X|)$  is an element of a quantifier, this is indicated by a '+'. To get used to the tree representation, one should try and answer some questions about numerical trees, such as the following. What are the tree patterns for *all*, *some*, *no* and *not all*? How are these patterns related? What are the relationships between the tree patterns for *at most three*, *exactly three*, and *at least three*? Figure 8 has some examples.

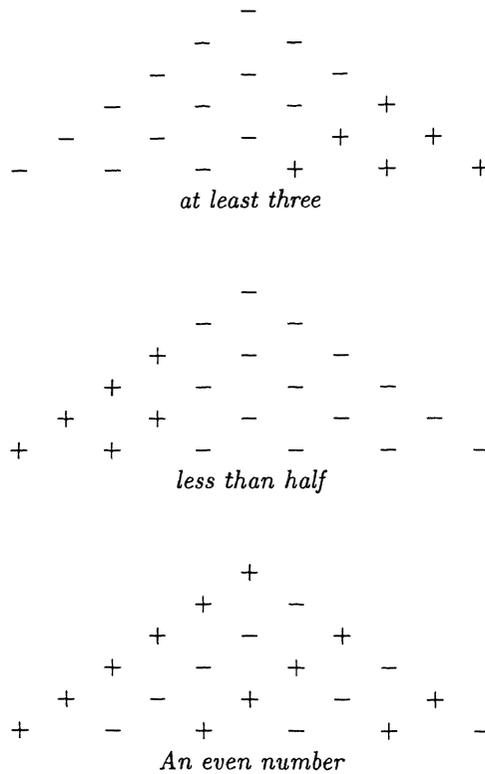

FIGURE 8 Examples of Numerical Trees

The tree of numbers can be used to *represent* quantifiers. But much more important is the observation that they give a *method of proof* (cf. Mostowski 1957, van Benthem 1984, 1986 Westerståhl 1984, a.o.). For instance, several quantifier properties translate to regularities of tree patterns. E.g., the tree pattern corresponding to  $\text{MON}\uparrow$  is: If a node has a +, then all nodes to the right on the same row have +s. And similarly with nodes to the left of a + in case of  $\text{MON}\downarrow$ . This 'geometry of quantifi-



$\nu$ . We claim that  $\nu$  characterizes  $\langle \mathbb{N}, < \rangle$  up to isomorphism. Clearly,  $\langle \mathbb{N}, <, \text{even} \rangle \models \nu$ . So assume  $\langle E, <, \mathbf{Q} \rangle \models \nu$ ,  $\mathbf{Q}$  a quantifier. Then  $\langle E, < \rangle$  is a discrete total order with an initial point but without an endpoint. This means that  $E$  is infinite. Due to (46) it holds of an arbitrary  $e \in E$  that either (i) the set of  $e$ 's predecessors is strictly smaller than that of its immediate successor  $f$ , or (ii) this  $f$  has strictly less successors. But (ii) cannot obtain: the sets of successors of  $e$  and  $f$  are unbounded, and hence both infinite. Since these sets differ in just one element they have the same size. Therefore (i) is true. Again, there is but one element in the difference of these sets. So  $E$  must be countable. From this one may deduce that  $\langle E, < \rangle$  is isomorphic to  $\langle \mathbb{N}, < \rangle$ : the initial point in  $E$  can be linked to 0, its immediate successor to 1, and so on...  $\square$

Theorem 11 makes clear that the expressive power of  $\text{EL}^{\mathbf{q}}$  exceeds that of  $\text{EL}^{\mathbf{wq}}$  (for, as we have seen,  $\text{EL}^{\mathbf{wq}}$  cannot define  $\langle \mathbb{N}, < \rangle$ ). By the same token we see that upward LST is false for  $\text{EL}^{\mathbf{q}}$ . Further,  $\text{EL}^{\mathbf{q}}$  is not complete: its set of valid sentences is not recursively enumerable. Using Gödel's theorems, Mostowski 1957 noted that a logic which defines the ordering of natural numbers is incomplete. Besides upward LST and completeness,  $\text{EL}^{\mathbf{q}}$  lacks compactness. Consider the theory  $\Gamma^{\mathbf{wo}}$ :

$$\Gamma^{\mathbf{wo}} := \{\nu\} \cup \{c_j < c_i : i, j \in \omega \text{ and } i < j\}$$

Each finite  $\Gamma_e \subseteq \Gamma^{\mathbf{wo}}$  has a model (interpret  $c_0$ , say, as the maximal subscript in  $\Gamma_e$  in  $\langle \mathbb{N}, <, \text{even} \rangle$ ). But  $\Gamma^{\mathbf{wo}}$  is unsatisfiable, since  $\mathbb{N}$  allows no infinite descending chains. (A total order with no such chains is called a *well-ordering*. On the assumption that  $\nu$  is first-order, the argument can be adapted to show that EL does not define well-orderings.) Finally,  $\text{EL}^{\mathbf{q}}$  does not have downward LST either. Thomason 1966 proved this, as follows. Let  $\Gamma$  be the theory in (47).

$$(47) \quad \Gamma := \Delta_{CUD} \cup \{Ac : c \in C\} \cup \{\neg Ad : d \in D\} \cup \{Qx.Ax \wedge \neg Qy.\neg Ay\}$$

with  $C$  and  $D$  disjoint countably infinite sets of constants, and  $\Delta_{CUD}$  as in (40). The theory  $\Gamma$  has an uncountable model. Take for example the real numbers with  $A$  interpreted as the natural numbers, and  $Qx\varphi$  as: 'there are at most countably many  $\varphi$ 's'. However,  $\Gamma$  has no countable model  $\langle E, \llbracket A \rrbracket, \mathbf{Q} \rangle$ . For in such a model  $|\llbracket A \rrbracket| = |E - \llbracket A \rrbracket|$ , which contradicts  $Qx.Ax \wedge \neg Qy.\neg Ay$  for any quantifier  $\mathbf{Q}$ . Cf. (44a).

All in all we see that the price for more expressiveness is rather high. The desirable metaproperties named in section 4.1.3 all have to go. In fact, other such properties suffer the same fate. Yasuhara 1969 shows that  $\text{EL}^{\mathbf{q}}$  has no LST theorems whatsoever. In particular, it has no downward variants with uncountable cardinals instead of the countable version given here. And therefore also no upward variants with a certain uncountable

cardinal as lowerbound. In this respect  $EL^q$  behaves on all models much like  $EL$  does on all finite ones.

At this point one may wonder whether there is a deeper reason as to why the search for an expressive system can only be satisfied at the loss of some of  $EL$ 's metaproperties. Such a reason is given by Lindström's theorems, which state that some combinations of these metaproperties can never be realised by logics stronger than  $EL$ . Let us say that a logic  $L$  *relativizes* (or: is closed under relativisation) iff for every sentence  $\varphi \in L$  and every one-place predicate constant  $P$  not in  $\varphi$ ,  $L$  defines a sentence  $\varphi^P$  with the property that  $\mathcal{M} \models \varphi^P$  iff  $\mathcal{M}|P^{\mathcal{M}} \models \varphi$  (here  $\mathcal{M}|P^{\mathcal{M}}$  is the submodel of  $\mathcal{M}$  with domain  $\llbracket P \rrbracket$ ). It is clear that  $EL$  relativizes.

**Theorem 12** (Lindström's theorems) *A logic  $L$  is equivalent to  $EL$  iff:*

1.  $L$  relativizes, has downward LST, and is either complete or has upward LST; or
2.  $L$  has downward LST and is compact.

For nice proof sketches, see Hodges 1983 and Lindström 1969. A more detailed proof can be found in Chang and Keisler 1990.

In the above we have restricted ourselves to comparing  $EL^q$  with  $EL$ . This is only the tip of an iceberg. In current investigations of extensions of  $EL$  much attention is paid to comparing their expressive power. In doing so one often uses other tools than compactness and LST theorems, simply because such means may not be present. A powerful tool is given by Ehrenfeucht-Fraïssé games. Westerståhl 1989 introduces their application to logics  $EL(Q)$ ,  $Q$  a binary quantifier. Cf. also Barwise and Cooper 1981, Kolaitis and Väänänen 1992, and Weese 1980, and the collection of papers Barwise and Feferman 1985.

Rather than stop here, with a logic which lacks many metaproperties, we consider a few variants of  $EL^q$ . First we show that the combination of  $\exists$ ,  $\forall$ , and  $Q$  gives  $EL^q$  its power. Once we eliminate  $\exists$  and  $\forall$ , a decidable logic remains. Finally, we end our introduction by considering some extensions of  $EL^{wq}$ .

#### 4.4 A Decidable Quantifier Logic

We have already seen that the logic  $EL^{wq}$  is undecidable. Anapolitanos and Anapolitanos and Väänänen 1981 made the nice observation that the logic  $L^{wq}$ , which is obtained from  $EL^{wq}$  by removing the  $\gamma$ 's and the  $\delta$ 's, is decidable. This is not difficult to see. In defining systematic tableaux for  $EL$  the  $\gamma$ 's are repeated, which results in possible infinite finished tableaux. But as soon as it is impossible to encounter any  $\gamma$ 's, i.e., by removing  $\gamma$ 's and negated  $\delta$ 's, the tableau construction is a finite process. Depending on the complexity of the root formula  $F\sigma$ , it halts in a fixed number of

steps. When it is finished we simply check whether the resulting tableaux is closed or open. In the first case  $\sigma$  is valid, in the second case it is invalid.

Observe that finite tableaux use only finitely many constants, so the model given by Hintikka's lemma will be finite. As a consequence, it can be proved that the logic  $L^Q$ , which is like  $L^{wQ}$  but now with  $Q$  varying over real quantifiers, is decidable too. This result of Anapolitanos and Väänänen" (1981) is obtained by showing that each weak finite model can be transformed into a finite model for  $L^Q$ . The proof uses the following lemma:

**Lemma 13** *Let  $X, Y \subseteq \{0, \dots, n\} = n + 1$ . We have:*

$$\sum_{n \in X} 2^n = \sum_{m \in Y} 2^m \Leftrightarrow X = Y$$

PROOF. The sums at the left-hand side are essentially codes of the subsets of  $n + 1$  using binary numerals. To see this, let  $X \subseteq n + 1$  and let  $f_X$  be the characteristic function of  $X$ . So,  $f_X(m) = 1$  if  $m \in X$ , otherwise  $f_X(m) = 0$ . Now consider the binary digit  $f_X(n) \dots f_X(0)$  (which may have some superfluous zero's to the left). The value of this digit is:  $f_X(n)2^n + \dots + f_X(0)$ , i.e.,  $\sum_{n \in X} 2^n$ . So if  $\sum_{n \in X} 2^n = \sum_{m \in Y} 2^m$  the corresponding binary digits are the same. Therefore the characteristic functions of the sets determined by these digits are identical, i.e.:  $X = Y$ .  $\square$

**Theorem 14** *If  $\varphi$  has a finite  $L^{wQ}$ -model, it has a finite  $L^Q$ -model.*

PROOF. Let  $\mathcal{A} = \langle A, \llbracket - \rrbracket_{\mathcal{A}}, \mathbf{Q} \rangle$  be a weak model with  $A = \{a_1, \dots, a_n\}$ . Choose sets  $A_i$  with  $|A_i| = 2^i$ , and  $A_i \cap A_j = \emptyset$  if  $i \neq j$ . Set  $B = \bigcup_n A_i$ . Let  $k : B \rightarrow A$  be the surjection with  $k(b) = a_i$ , for all  $b \in A_i$ . So  $k^{-1}(a_i) = \{b \in B : k(b) = a_i\} = A_i$ . Define  $\mathcal{B} = \langle B, \llbracket - \rrbracket^{\mathcal{B}}, \mathbf{Q}^* \rangle$  by:

$$\begin{aligned} \llbracket R \rrbracket^{\mathcal{B}} &:= \{ \langle b_1, \dots, b_n \rangle : \llbracket R \rrbracket^{\mathcal{A}}(k(b_1), \dots, k(b_n)) \} \\ \mathbf{Q}^* &:= \{ Y \subseteq B : \exists X \in \mathbf{Q} [|Y| = |k^{-1}(X)|] \} \end{aligned}$$

with  $k^{-1}(X) = \{b \in B : k(b) \in X\}$ . We claim that:

$$\mathcal{B} \models \varphi(\underline{b}_1, \dots, \underline{b}_n) \Leftrightarrow \mathcal{A} \models \varphi(\underline{k(b_1)}, \dots, \underline{k(b_n)})$$

(Recall that  $\underline{b}$  denotes  $b$ . In fact we write  $\underline{b}$  for  $\underline{b}_1, \dots, \underline{b}_n$ , below, and similarly for  $\underline{k(b)}$ .) The atomic and the Boolean cases are straightforward. We concentrate on quantified sentences. By induction hypothesis we have:

$$\widehat{x}. \llbracket \varphi(x, \underline{b}) \rrbracket^{\mathcal{B}} = k^{-1}(\widehat{x}. \llbracket \varphi(x, \underline{k(b)}) \rrbracket^{\mathcal{A}})$$

Using this, the proof from right to left is simple:

$$\begin{aligned}
 & \mathcal{A} \models Qx.\varphi(x, k(b)) \\
 \Rightarrow & \hat{x}.\llbracket \varphi(x, k(b)) \rrbracket^A \in \mathbf{Q} \\
 \Rightarrow_{i.h.} & \hat{x}.\llbracket \varphi(x, k(b)) \rrbracket^A \in \mathbf{Q} \\
 & \quad \& |\hat{x}.\llbracket \varphi(x, b) \rrbracket^B| = |k^{-1}(\hat{x}.\llbracket \varphi(x, k(b)) \rrbracket^A)| \\
 \Rightarrow & \hat{x}.\llbracket \varphi(x, b) \rrbracket^B \in \mathbf{Q}^* \\
 \Rightarrow & \mathcal{B} \models Qx.\varphi(x, b)
 \end{aligned}$$

From left to right we reason as follows:

$$\begin{aligned}
 & \mathcal{B} \models Qx.\varphi(x, b) \\
 \Rightarrow & \hat{x}.\llbracket \varphi(x, b) \rrbracket^B \in \mathbf{Q}^* \\
 \Rightarrow & \exists X \in \mathbf{Q} : |\hat{x}.\llbracket \varphi(x, b) \rrbracket^B| = |k^{-1}(X)| \\
 \Rightarrow_{i.h.} & \exists X \in \mathbf{Q} : |k^{-1}(\hat{x}.\llbracket \varphi(x, k(b)) \rrbracket^A)| = |k^{-1}(X)| \\
 \Rightarrow & \exists X \in \mathbf{Q} : \sum_{a_i \in \hat{x}.\llbracket \varphi(x, k(b)) \rrbracket^A} 2^i = \sum_{a_j \in X} 2^j \\
 \Rightarrow & \exists X \in \mathbf{Q} : \hat{x}.\llbracket \varphi(x, k(b)) \rrbracket^A = X \\
 \Rightarrow & \mathcal{A} \models Qx.\varphi(x, k(b))
 \end{aligned}$$

The fifth step uses lemma 13. □

It would be interesting to know which quantifier properties are preserved under the above construction.

## 4.5 Extensions of Weak Quantifier Logic

It is natural to ask whether the results for  $\text{EL}^{\text{wq}}$  can be generalized to quantifiers with more properties than just extensionality. Here we shall briefly mention two such extensions. The first concerns universal properties of quantifiers, the second quantifiers which are closed under some but perhaps not all permutations.

### 4.5.1 Universal Properties

A universal property of a quantifier is one which can be stated as a universal sentence in the second-order extension of  $\text{EL}^{\text{wq}}$ . In this extension we may quantify over subsets of the domain. A universal sentence is of the form:

$$(48) \quad \forall X_1 \dots X_n. \Psi(X_1 \dots X_n)$$

where  $\Psi$  is a sentence in first-order  $\text{EL}^{\text{wq}}$  with  $X_1 \dots X_n$  second-order variables acting as predicates. The sentence (48) is true in a model  $\mathcal{M}$  iff

$$\langle \mathcal{M}, A_1 \dots A_n \rangle \models \Psi(Q, X_1 \dots X_n)$$

for all subsets  $A_1 \dots A_n$  of  $\mathcal{M}$ . Examples of universal properties are:

$$(49) \quad \begin{array}{ll} \text{MON}\uparrow & \forall XY[(\mathbf{Q}_E X \wedge X \subseteq Y) \Rightarrow \mathbf{Q}_E Y] \\ \text{MON}\downarrow & \forall XY[(\mathbf{Q}_E Y \wedge X \subseteq Y) \Rightarrow \mathbf{Q}_E X] \\ \text{MEET} & \forall XY[(\mathbf{Q}_E X \wedge \mathbf{Q}_E Y) \Rightarrow \mathbf{Q}_E X \cap Y] \\ \text{SPLITTING} & \forall XY[\mathbf{Q}_E X \cup Y \Rightarrow (\mathbf{Q}_E X \vee \mathbf{Q}_E Y)] \\ \text{CONSISTENCY} & \forall XY[\mathbf{Q}_E X \Rightarrow (\neg \mathbf{Q}_E \bar{X})] \\ \text{COMPLETENESS} & \forall XY[(\neg \mathbf{Q}_E \bar{X}) \Rightarrow \mathbf{Q}_E X] \end{array}$$

Following up on Westerståhl 1989, appendix B, Doets 1991 shows that in general the logic  $\text{EL}^{\mathbf{wq}}(\mathbf{P})$ ,  $\mathbf{P}$  a universal quantifier property, is still complete, compact, and has LST theorems. Here we concentrate on the special case of the splitting quantifiers to get a feel for the issues involved.

In order to show that  $\text{EL}^{\mathbf{wq}}(\text{SPLITTING})$  is complete, we may use Hintikka sets  $S$  which contain all signed sentences of the form:

$$(50) \quad \text{T}[Qx(\varphi \vee \psi) \rightarrow Qx\varphi \vee Qx\psi]$$

In a model of such a Hintikka set,  $\mathbf{Q}$  will be splitting on the definable sets.

**Definition 10** A set  $X \subseteq E$  is definable in a model  $\mathcal{M}$  on  $E$  with names for each of its elements iff there is a formula  $\varphi(x)$  such that  $X = \hat{x}.\llbracket\varphi(x)\rrbracket^{\mathcal{M}}$ . We use  $\text{DEF}_{\mathcal{M}}$  for the set of all definable sets in  $\mathcal{M}$ .

It is not enough to ensure that  $\mathbf{Q}$  is splitting on the definable sets; it needs to be splitting on *all* sets. Fortunately, if  $\mathbf{Q}$  is splitting on the definable sets then it is always possible to find a  $\mathbf{Q}^*$  which is splitting on all sets and identical to  $\mathbf{Q}$  on the definable ones. Using this, we can prove Hintikka's lemma.

**Proposition 15** *If  $[\mathbf{Q}]^{\mathcal{M}}$  is splitting on  $\text{DEF}_{\mathcal{M}}$  then  $[\mathbf{Q}^*]^{\mathcal{M}}$  defined by:*

$$[\mathbf{Q}^*]^{\mathcal{M}} := \{X \subseteq E : \neg \text{DEF}_{\mathcal{M}} \bar{X} \vee \mathbf{Q}_E X\}$$

*is equal to  $[\mathbf{Q}]^{\mathcal{M}}$  on  $\text{DEF}_{\mathcal{M}}$  and is splitting on all sets.*

**PROOF.** It is clear that  $[\mathbf{Q}^*]^{\mathcal{M}}$  and  $[\mathbf{Q}]^{\mathcal{M}}$  are identical on the definable sets (for if  $X$  is definable so is  $\bar{X}$ ). It remains to show that  $[\mathbf{Q}^*]^{\mathcal{M}}$  is splitting on all sets. So assume that  $[\mathbf{Q}^*]^{\mathcal{M}}(X \cup Y)$ . We distinguish two cases. (i)  $\neg \text{DEF}_{\mathcal{M}}(\bar{X} \cup \bar{Y})$ . Since  $\text{DEF}_{\mathcal{M}}$  is closed under Boolean operations, it follows that  $\neg \text{DEF}_{\mathcal{M}}(\bar{X})$  or  $\neg \text{DEF}_{\mathcal{M}}(\bar{Y})$ . Therefore by definition  $[\mathbf{Q}^*]^{\mathcal{M}}(X)$  or  $[\mathbf{Q}^*]^{\mathcal{M}}(Y)$ . (ii)  $\text{DEF}_{\mathcal{M}}(\bar{X} \cup \bar{Y})$ . Combined with the fact that  $[\mathbf{Q}^*]^{\mathcal{M}}(X \cup Y)$ , we now have:  $[\mathbf{Q}]^{\mathcal{M}}(X \cup Y)$ . But  $\mathbf{Q}_{\mathcal{M}}$  is splitting on the definable sets. So  $[\mathbf{Q}]^{\mathcal{M}}(X)$  or  $[\mathbf{Q}]^{\mathcal{M}}(Y)$ , and therefore  $[\mathbf{Q}^*]^{\mathcal{M}}(X)$  or  $[\mathbf{Q}^*]^{\mathcal{M}}(Y)$ .  $\square$

In order to prove completeness from Hintikka's lemma it remains to alter the notion of a systematic tableau so as to make sure that each of its open branches includes all instances of (50). If for simplicity we assume there

are countably many of such sentences this is simple. Just treat them as premisses, which we already know how to handle.

As we said earlier, Doets 1991 has a general argument—using an Ehrenfeucht–Fraïssé game—showing that for each  $EL^{wq}(\mathbf{P})$  the set of valid sentences is recursively enumerable, where  $\mathbf{P}$  is a universal quantifier property. We refer to his paper for details.

#### 4.5.2 Generalized Interpretations for $EL^q$

It is clear that not all quantifier properties can be cast in a universal mould. Here are two examples from Doets 1991:

- (51) a.  $QxQy.\varphi \leftrightarrow QyQx.\varphi$   
 b.  $Qx\exists y.\varphi \wedge \forall xQy.\varphi \rightarrow Qy\exists x\varphi$

The property (51a) states that  $Q$  is self-commuting; it is the ‘Fubini’ property of *almost all* on its measure theoretic interpretation. And (51b) is an axiom for *there are at most countable many*, which states that the union of countably many sets is itself countable. Cf. Van Lambalgen, this volume, and Westerståhl 1994b.

Another property which falls outside the scope of Doets’ result is closure under definable permutations. This property is introduced by Thomason and Johnson, jr. 1969, and given by the axiom in (52).

$$(52) (\forall x\exists!y\varphi \wedge \forall y\exists!x\varphi \wedge \forall y[\psi \leftrightarrow \exists x(\varphi \wedge \chi)]) \rightarrow (Qy\psi \leftrightarrow Qx\chi)$$

Here  $\exists!z$  reads as ‘exactly one  $z$ ’. Note that (52) is a strengthening of axiom (33b), which is the special case with  $\varphi \equiv x = y$ .

In the antecedent of (52)  $\forall x\exists!y\varphi \wedge \forall y\exists!x\varphi$  forces the two place relation  $\widehat{xy}.\varphi$  to be a bijection, call it  $f$ . And  $\forall y[\psi \leftrightarrow \exists x(\varphi \wedge \chi)]$  states that the set  $\widehat{y}.\psi$  is the image of the set  $\widehat{y}.\chi$  under  $f$ :  $\widehat{y}.\psi = f(\widehat{x}.\chi)$ . In other words, if (52) is true for all  $\varphi$ ,  $\psi$ , and  $\chi$ , then on the definable sets  $Q$  is invariant for definable permutations.

Section 4.3.2 has taught us that we cannot hope for completeness by finding a suitable variant of  $Q$  which extends this property to all sets and all permutations;  $EL^q$  is incomplete. Still, the axiom scheme (52) can be used to obtain the nice extension  $EL^{dq}$  of  $EL^{wq}$ , which is complete, compact and has LST theorems. This logic uses generalized models, along the lines of Henkin’s models for higher-order logic (cf. van Benthem and Doets 1983). The generalized models are of the form:

$$\langle E, [-], \mathbf{Q}, \mathbf{P} \rangle$$

with  $\mathbf{P}$  a subset of the set of all permutations on  $E$ , and  $\mathbf{Q}$  a set of subsets of  $E$  which satisfies:

$$\mathbf{Q}X \Leftrightarrow \mathbf{Q}\pi(X)$$

for all  $X \subseteq E$  and all  $\pi \in \mathbf{P}$ . In order to make (52) valid, we have to require that in a generalized  $\mathcal{M}$ ,  $\mathbf{P}$  contains all definable permutations.

$$(53) \quad \mathcal{M} \models \widehat{xy}.\varphi \text{ is a bijection}' \Rightarrow \widehat{xy}.\llbracket\varphi\rrbracket_{\mathcal{M}} \in \mathbf{P}$$

Given this much, it is not too difficult to prove  $\text{EL}^{\text{dp}}$  to be complete. Again, we refer to the original paper for details.

## References

- Anapolitanos, D.A., and J.A. Väänänen. 1981. Decidability of some Logics with Free Quantifier Variables. *Zeitschr. f. math. Logik und Grundlagen d. Math.* 27:17–22.
- Asher, Nicolas, and Dan Bonevac. 1987. How Extensional is Extensional Perception? *Linguistics and Philosophy* 8:203–228.
- Asher, Nicolas, and Dan Bonevac. 1989. Determiners and Resource Situations. *Linguistics and Philosophy* 10:567–596.
- Barwise, Jon. 1979. On Branching Quantifiers in English. *Journal of Philosophical Logic* 8:47–80.
- Barwise, Jon. 1981. Scenes and other Situations. *Journal of Philosophy* LXXVIII:369–397.
- Barwise, Jon, and Robin Cooper. 1981. Generalized Quantifiers and Natural Language. *Linguistics and Philosophy* 4:159–219.
- Barwise, Jon, and Salomon Feferman (ed.). 1985. *Model-Theoretic Logics*. New York: Springer-Verlag.
- Barwise, Jon, and John Perry. 1983. *Situations and Attitudes*. Cambridge, Massachusetts: The M.I.T. Press.
- Ben-Shalom, Dorit. 1994. A Tree Characterization of Generalized Quantifier Reducibility. In *Dynamics, Polarity, and Quantification*, ed. Makoto Kanazawa and Chris Piñón. 147–171. Stanford, California: CSLI Publications.
- Chang, C. C., and H. J. Keisler. 1990. *Model Theory*. Studies in Logic and the Foundations of Mathematics, Vol. 73. Amsterdam: North-Holland. Third edition edition. First edition: 1973.
- Dalrymple, Mary, Makoto Kanazawa, Sam Mchombo, and Stanley Peters. 1994. What Do Reciprocals Mean? In *Proceedings of the Fourth Semantics and Linguistics Conference: SALT IV*, ed. Mandy Harvey and Lynn Santelmann. Cornell University Working Papers in Linguistics.
- Doets, Kees. 1991. Axiomatizing Universal Properties of Quantifiers. *Journal of Symbolic Logic* 56:901–905.
- Gurevich, Y. 1985. Logic and the Challenge of Computer Science. Report CRL-TR-10–85. University of Michigan, Ann Arbor: Computing Research Laboratory.
- Heim, Irene. 1982. *The Semantics of Definite and Indefinite Noun Phrases*. Doctoral dissertation, University of Massachusetts, Amherst.
- Higginbotham, James. 1983. The Logic of Perceptual Reports: An Extensional Alternative to Situation Semantics. *Journal of Philosophy* LXXX:100–127.

- Higginbotham, James, and Robert May. 1981. Questions, Quantifiers, and Crossing. *The Linguistic Review* 1:41-79.
- Hintikka, Jaakko. 1974. Quantifiers vs. Quantification Theory. *Linguistic Inquiry* 5:153-177.
- Hodges, Wilfred. 1983. Elementary Predicate Logic. In *Handbook of Philosophical Logic*, ed. Dov Gabbay and Frans Guenther. 1-131. Dordrecht: D. Reidel Publishing Company.
- Kamp, Hans. 1981. A Theory of Truth and Semantic Representation. In *Formal Methods in the Study of Language*, ed. Jeroen Groenendijk, Theo Janssen, and Martin Stokhof. 277-322. Amsterdam: Mathematical Centre.
- Kamp, Hans. 1984. A Scenic Tour through the Land of Naked Infnitives. Unpublished Manuscript.
- Keenan, Edward L. 1987a. A Semantic Definition of 'Indefinite NP'. In *The Representation of (In)definites*, ed. Eric Reuland and Alice ter Meulen. 286-317. Cambridge, Massachusetts: The M.I.T. Press.
- Keenan, Edward L. 1987b. Unreducible  $n$ -ary Quantifiers in Natural Language. In *Generalized Quantifiers: Linguistic and Logical Approaches*, ed. Peter Gärdenfors. 109-150. Dordrecht: D. Reidel Publishing Company.
- Keenan, Edward L. 1992. Beyond the Frege Boundary. *Linguistics and Philosophy* 15:199-221. Revised version republished in this collection.
- Keenan, Edward L., and J. Stavi. 1986. A Semantic Characterization of Natural Language Determiners. *Linguistics and Philosophy* 9:253-326.
- Keenan, Edward L., and D. Westerståhl. 1995. Generalized Quantifiers in Linguistics and Logic. In *Handbook of Linguistics and Logic*, ed. Johan van Benthem and Alice ter Meulen. Amsterdam: Elsevier.
- Keisler, H.J. 1970. Logic with the Quantifier 'There exist uncountably many'. *Annals of Mathematical Logic* 1:1-93.
- Kolaitis, Phokion, and Jouko Väänänen. 1992. Generalized Quantifiers and Pebble Games on Finite Structures. In *Proceedings of the 7th IEEE Symposium on Logic in Computer Science*. 348-359. To appear in *Annals of Pure and Applied Logic*.
- Langholm, Tore. 1988. *Partiality, Truth, and Persistence*. Lecture Notes. Stanford, California: CSLI Publications.
- Lewis, David. 1975. Adverbs of Quantification. In *Formal Semantics of Natural Language*, ed. Edward L. Keenan. 3-15. Cambridge: Cambridge University Press.
- Lindström, Per. 1966. First-order Predicate Logic with Generalized Quantifiers. *Theoria* 32:186-195.
- Lindström, Per. 1969. On Extensions of Elementary Logic. *Theoria* 35:1-11.
- Milsark. 1977. Toward an Explanation of Certain Peculiarities of the Existential Construction in English. *Linguistic Analysis* 3(1):1-30.
- Mostowski, Andrzej. 1957. On a Generalization of Quantifiers. *Fundamenta Mathematicae* 44:12-36.
- Muskens, Reinhard. 1989. *Meaning and Partiality*. Doctoral dissertation, University of Amsterdam, Amsterdam.

- Scha, Remko. 1981. Distributive, Collective, and Cumulative Quantification. In *Formal Methods in the Study of Language*, ed. Jeroen Groenendijk, Theo Janssen, and Martin Stokhof. 483–512. Amsterdam: Mathematical Centre.
- Sher, Gila. 1990. Ways of Branching Quantifiers. *Linguistics and Philosophy* 13:393–422.
- Smullyan, Raymond M. 1968. *First-order Logic*. Berlin: Springer-Verlag.
- Thomason, Richmond. 1966. A System of Logic with Free Variables ranging over Quantifiers (abstract). *Journal of Symbolic Logic* 31:700.
- Thomason, Richmond H., and Johnson, jr. 1969. Predicate Calculus with Free Quantifier Variables. *Journal of Symbolic Logic* 34(1):1–7.
- Trahtenbrot, B.A. 1950. The Impossibility of an Algorithm for the Decision Problem for Finite Domains. *Doklady Akademii Nauk SSSR* 70:569–572.
- Väänänen, Jouko. 1978. Remarks on Free Quantifier Variables. In *Essays on Mathematical and Philosophical Logic*, ed. J. Hintikka, I. Niiniluoto, and E. Saarinen. 267–272. Dordrecht: D. Reidel Publishing Company.
- van Benthem, Johan. 1984. Questions about Quantifiers. *Journal of Symbolic Logic* 49(2):443–466.
- van Benthem, Johan. 1986. *Essays in Logical Semantics*. Studies in Linguistics and Philosophy, Vol. 29. Dordrecht: D. Reidel Publishing Company.
- van Benthem, Johan. 1989. Polyadic Quantifiers. *Linguistics and Philosophy* 12:437–464.
- van Benthem, Johan, and Kees Doets. 1983. Higher-order Logic. In *Handbook of Philosophical Logic*, ed. Dov Gabbay and Frans Geunthner. 275–329. Dordrecht: D. Reidel Publishing Company.
- van Benthem, Johan, and Dag Westerståhl. 1994. Directions in Generalized Quantifier Theory. Research Report LP-94-06. Amsterdam: ILLC, University of Amsterdam. To appear in *Studia Logica*.
- van der Does, Jaap. 1991. A Generalized Quantifier Logic for Naked Infinitives. *Linguistics and Philosophy* 14:241–294.
- van Eijck, Jan. 1985. Generalized Quantifiers and Traditional Logic. In *Generalized Quantifiers in Natural Language*, ed. Johan van Benthem and Alice ter Meulen. GRASS Vol. 4. Dordrecht: Foris.
- van Eijck, Jan. 1991. Quantification. In *Semantics. An International Handbook of Contemporary Research*, ed. D. Wunderlich and A. von Stechow. Berlin.
- Weese, M. 1980. Generalized Ehrenfeucht Games. *Fundamenta Mathematicae* 109:103–112.
- Westerståhl, Dag. 1984. Some Results on Quantifiers. *Notre Dame Journal of Formal Logic* 25:152–170.
- Westerståhl, Dag. 1987. Branching Generalized Quantifiers and Natural Language. In *Generalized Quantifiers: Linguistic and Logical Approaches*, ed. Peter Gärdenfors. 109–150. Dordrecht: D. Reidel Publishing Company.
- Westerståhl, Dag. 1989. Quantifiers in Formal and Natural Language. In *Handbook of Philosophical Logic*, ed. Dov Gabbay and Frans Geunthner. 1–131. Dordrecht: D. Reidel Publishing Company.

- Westerståhl, Dag. 1994a. Iterated Quantifiers. In *Dynamics, Polarity, and Quantification*, ed. Makoto Kanazawa and Chris Piñón. 173–209. Stanford, California: CSLI Publications.
- Westerståhl, Dag. 1994b. Self-Commuting Quantifiers. Unpublished Manuscript, Stockholm University. To appear in JSL.
- Westerståhl, Dag. 1995. Quantifiers in Natural Language: A Survey of Some Recent Work. In *Quantifiers*, ed. Michal Krynicki and Marcin Mostowski. Dordrecht: D. Reidel Publishing Company.
- Yasuhara, M. 1969. The Incompleteness of  $L_p$  Languages. *Fundamenta Mathematicae* 66:147–152.